

DryCal® ML-350 Manual

DryCal ML-350 Specifications

Size 7.69" H x 5.93" W x 3.76" D • 19.53 cm H x 15.06 cm W x 9.55 cm D

Weight 4.7 lbs • 2.1 kg

Flow Ranges

Model	Optimum Flow Range
ML-350-10	5–500 sccm
ML-350-24	50–5,000 sccm
ML-350-44	500–50,000 sccm*

* Maximum flow rate is 50,000 sccm at sea level, at higher altitudes piston may not return at flow rates higher than 40,000 sccm.

Absolute Accuracy, Single Readings

All accuracies are based on % of readings. Averaging multiple readings will increase repeatability and accuracy.

Model	Volumetric (5°–40°C)	Standardized (15°–30°C)
ML-350-10	±0.5%	±0.75%
ML-350-24	±0.5%	±0.75%
ML-350-44**	±0.5%	±0.75%

** 30,000–50,000 sccm at ±0.30% volumetric accuracy, ±0.45% standardized

Suitable Gases Non-corrosive, humidity less than 80%, non-condensing

Time per Reading Approximately 1 to 15 seconds, flow & model dependent

Operating Modes Single cycle, continuous cycling or 1 to 255 minute intervals

Flow Cell Graphite composite piston in borosilicate glass cylinder

Temperature Range 15–30 C

Temperature & Pressure Sensors Solid state, located at entrance to flow cell

Battery System Internal continuously chargeable sealed 6V lead-acid battery

AC Charger | Adapter Choice of 100 VAC, 50Hz or 100–125 VAC, 60 Hz or 200–240 VAC 50–60 Hz

Fittings ¼" Swagelok® fittings standard, with 3/8" and ½" Swagelok® fittings available

Self-Test Leakage

Outputs Illuminated LCD display, serial port (printer or CSV format)

Warranty Product, 1 year; battery, 6 months

Annual calibration offered by Bios is elective and is not included as a warranty item.

All specifications are subject to change. Please contact Bios or visit our web site at www.drycal.com for the most current product information.

Table of Contents

1.0	ML-350 Menu Tree	1-2
2.0	ML-350 Features	3
3.0	Unpacking Checklist	4
4.0	Warnings	4
5.0	General Description	4
6.0	Theory of Operation	5-6
7.0	Operating Instructions	6-7
7.1	ML-350 Keypad	7
7.2	How to Use the ML-350 Keypad	7
7.3	Factory Default Settings	8
7.4	Connecting the ML-350 to a Flow Source	8
7.5	Taking Readings	8-9
8.0	Setting User Preferences	9
8.1	Setup Menu 1, Calibration ID #, Gas Constant, Calibration Type	9
8.2	Setup Menu 2, Reading Type, # in Average, Minutes/Reading	10
8.3	Setup Menu 3, Temp. Correction Factor, Temp. & Pressure Formats	10
8.4	Setup Menu 4, Date, Time & Battery Voltage	10-11
8.5	Setup Menu 5, Date & Time Formats	11
8.6	Setup Menu 6, Leakage & LCF (Leakage Correction Factor)	11-12
9.0	Printing	12
9.1	ML-350 Printer Menu	12
9.2	Printing "Real-Time" Data	12-13
10.0	Battery System	13
10.1	Charging the ML-350	13
10.2	Battery Maintenance & Storage	13
11.0	Maintenance, Quality Assurance	14
11.1	Leak Test Procedure	14-15
11.2	Calibration	15
11.3	Returning Your Unit for Calibration or Service	15
11.4	Shipment	15
11.5	Replacement Parts & Accessories	16
12.0	Limited Warranty	17
Appendices		
A	ML-350 Trouble-Shooting Guide	18-20

1.0 ML-350 Menu Trees

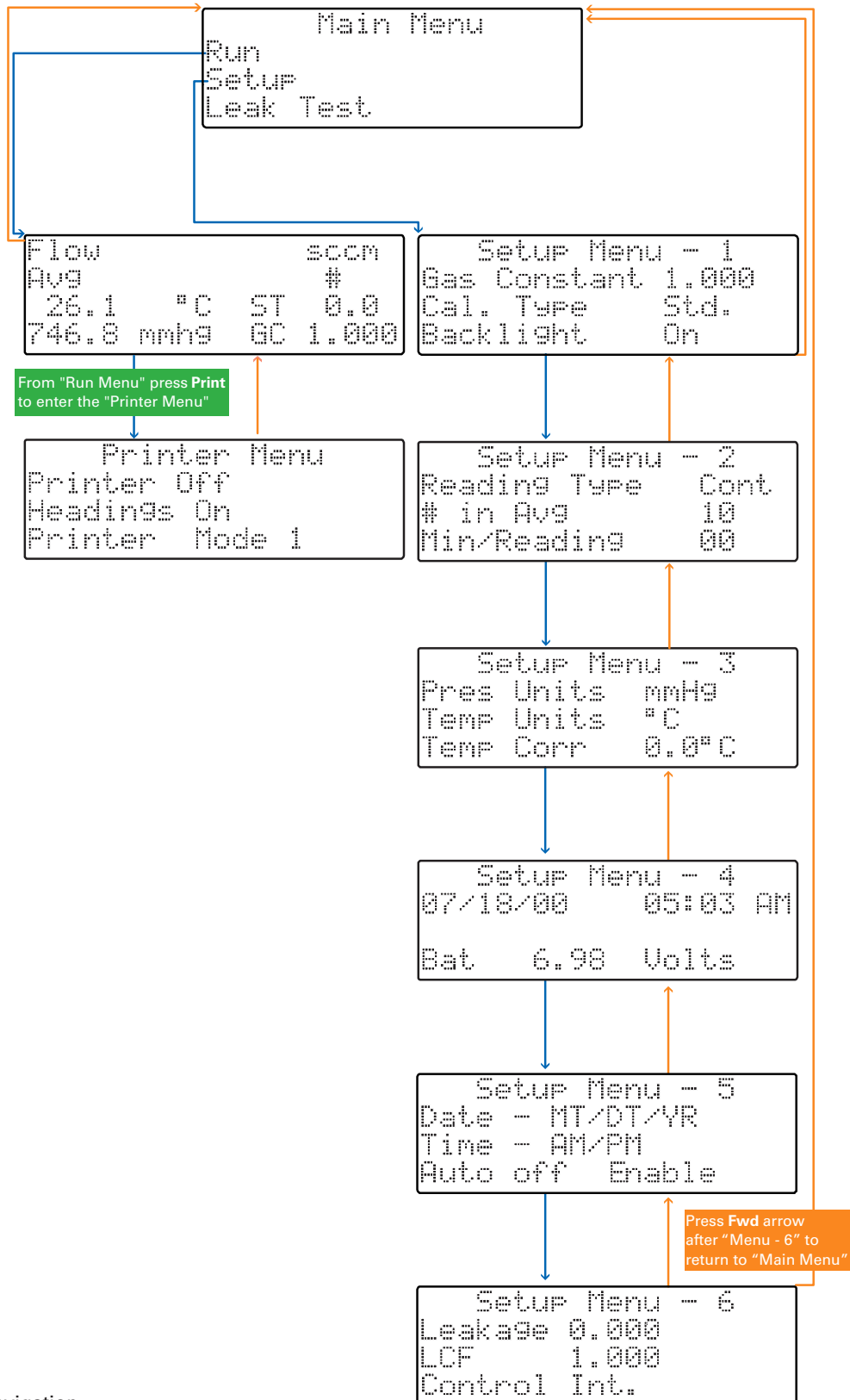

- = Forward navigation
- = Backward navigation
- Use the Up/Down arrows to navigate between different lines.
- Use the Enter button to select a field to be modified depending on the function and to lock in any changes.
- Use either the keypad or the Up/Down arrows to modify the desired field.
- Use the Fwd and Back keys to advance to the following menu or return to the previous menu.

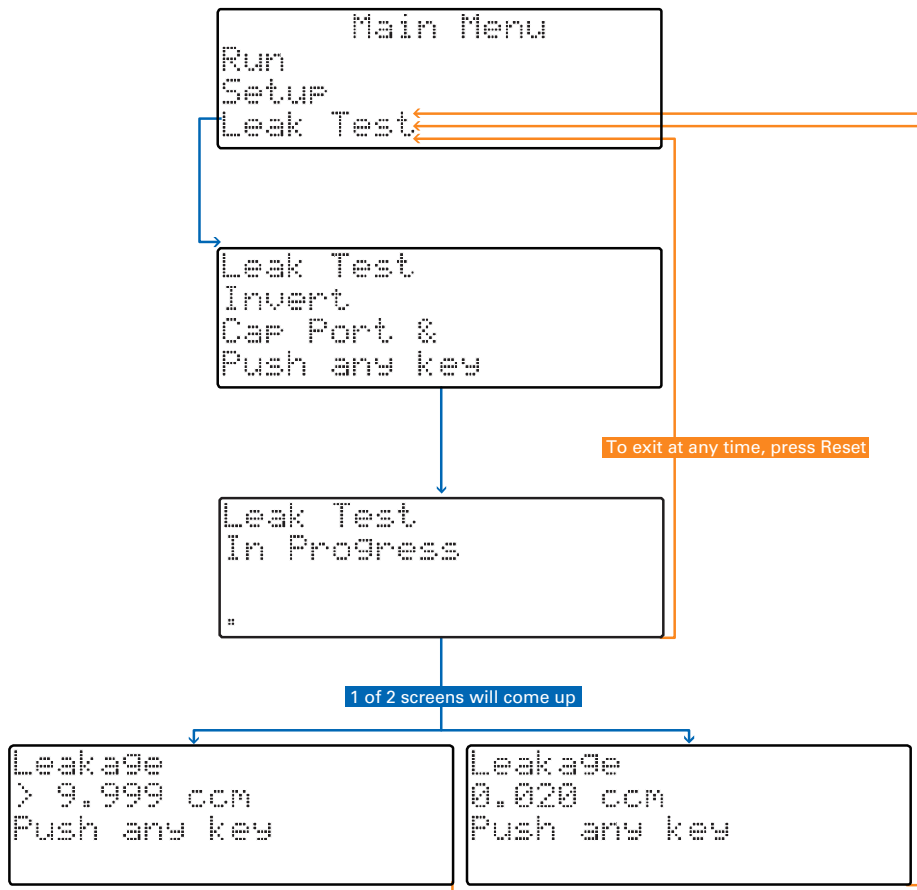

Error Messages

```
Piston Error
```

Piston did not return to bottom of cell properly.
To exit, press any key.

- = Forward navigation
- = Backward navigation
- Use the Up/Down arrows to navigate between different lines.
- Use the Enter button to select a field to be modified depending on the function and to lock in any changes.
- Use either the keypad or the Up/Down arrows to modify the desired field.
- Use the Fwd and Back keys to advance to the following menu or return to the previous menu.

2.0 ML-350 Features

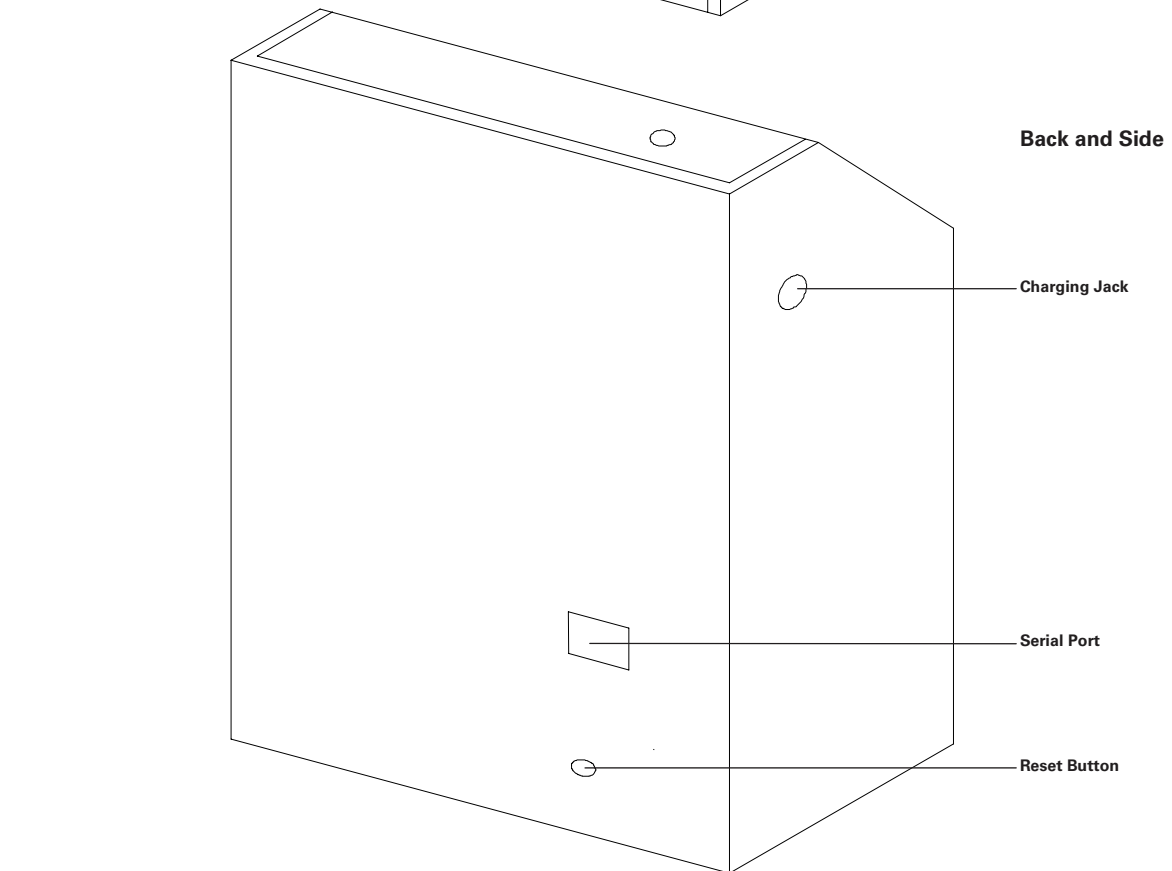
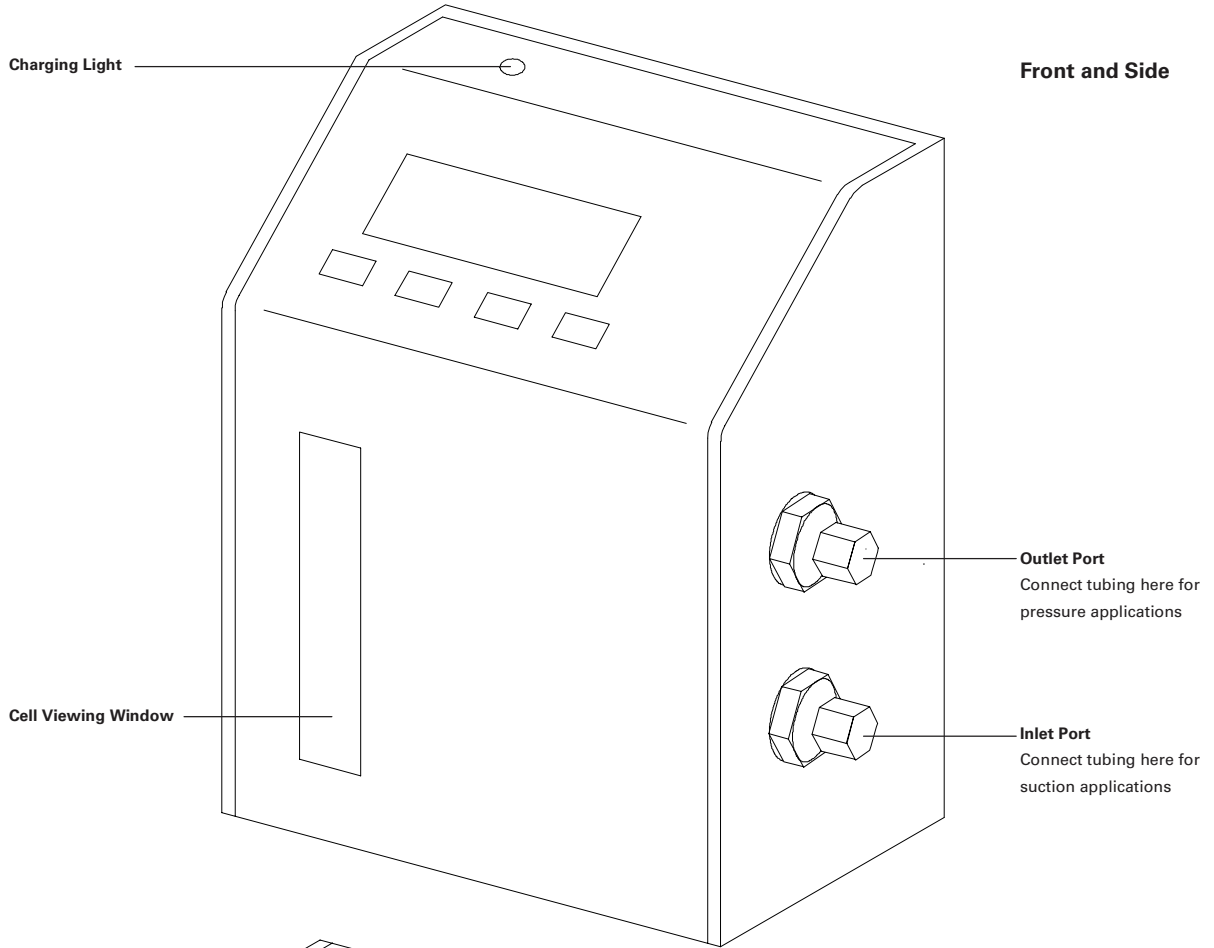

3.0 Unpacking Checklist

Your DryCal ML-350 has been packaged with care and includes all components necessary for complete operation. Please take a moment to check that you have received the following items. If you believe you have not received a full shipment or if you have any questions, please contact Bios immediately.

Your DryCal ML-350 Includes

- ML-350
- Battery Charger
- RS-232 Cable
- DryCal Communications Program CD ROM
- Instruction Manual, Application Guide, and DryCal Communications Program Installation Instructions
- Barbed Adapter
- Leak Test Plug
- Certificate of Calibration
- Warranty Card

4.0 Warnings

 The ML-350 is not rated intrinsically safe and is not for use with explosive gasses or for use in explosive environments.

 The ML-350 is not designed for pressurization above 0.35 bar (5 PSI) or for gas flows above the rated specifications of the flow model in use. Please consult the product specification on the inside front cover of the manual for more information regarding acceptable gas flow ranges or visit our website at www.drycal.com for the most current product specifications.

 For use with clean laboratory air or other inert, non-corrosive gasses only.

5.0 General Description

The DryCal ML-350 can be used to measure gas flow rates for either a pressure or a vacuum flow source. Using near-frictionless piston technology, it combines the accuracy of a primary standard with unequalled speed and convenience.

Volumetric or Standardized flow readings are obtained with the push of a button. The DryCal can be set to take flow readings manually, one reading at a time, or automatically in the auto-read mode. The ML-350 can be programmed for up to 100 readings in an averaging sequence.

The ML-350 includes an RS-232 (Serial) Port for computer interface capability using The DryCal Communication Program (See *DryCal Communication Program Installation Instructions*). The Serial Port can also be used for hardcopy printing of flow readings using the BP-1 portable thermal printer. Additional buttons provide access to user-definable parameters, such as calibration or asset identification numbers.

6.0 Theory of Operation

The DryCal ML-350 is a true primary gas standard. The time required for the graphite composite piston to traverse a known distance through the flow cylinder is precisely measured and an internal computer calculates the flow. The volumetric accuracy of the instrument is built into its dimensional characteristics. Standardization of the gas flow readings is achieved with precisely calibrated temperature and pressure sensors.

Piston provers like the DryCal are characterized by the most basic of quantities: length and time. As flow is necessarily a derived unit, a dimensionally characterized system would be as close as possible to direct traceability from national dimensional standards.

An idealized piston prover would consist of a massless, frictionless, leakproof, shape-invariant and impermeable piston inserted within the flow stream and enclosed by a perfect cylinder (Figure 1). The time that the piston takes to move a known distance (which implies a known volume) then yields the volumetric flow as:

$$F = V/T = \pi r^2 h / T$$

Such a device would be as accurate as its physical dimensions and its clock, with almost insignificant drift mechanisms. Although such idealized devices do not exist, we believe the DryCal offers close to ideal performance.

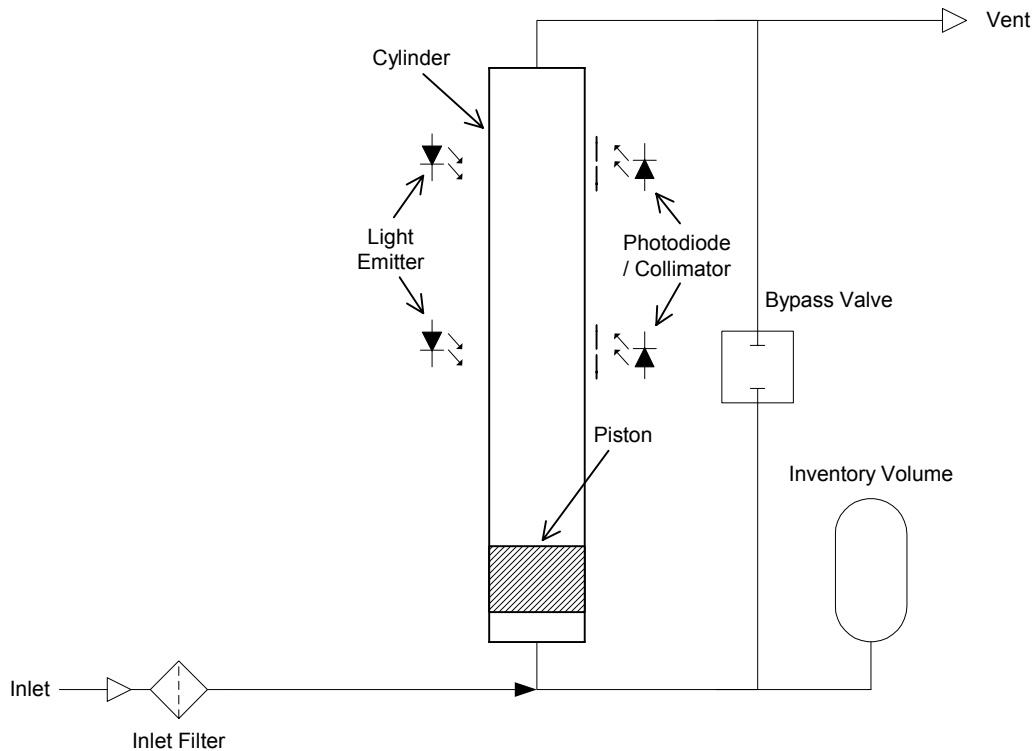

Figure 1 Idealized Automatic Piston Prover

The DryCal clearance-sealed prover uses a piston and cylinder fitted so closely that the viscosity of the gas under test results in a leakage small enough to be insignificant. For reasonable leakage rates, such a gap must be approximately 10 microns. As a practical matter, the piston and cylinder are made of graphite and borosilicate glass because of their low, matched temperature coefficients of expansion and low friction.

In order to make an intrinsically volumetric device useful, it is generally necessary to adjust the readings to a standardized temperature and pressure. For this reason, we include temperature and pressure transducers to allow computation of standard flow by the internal computer (Figure 2).

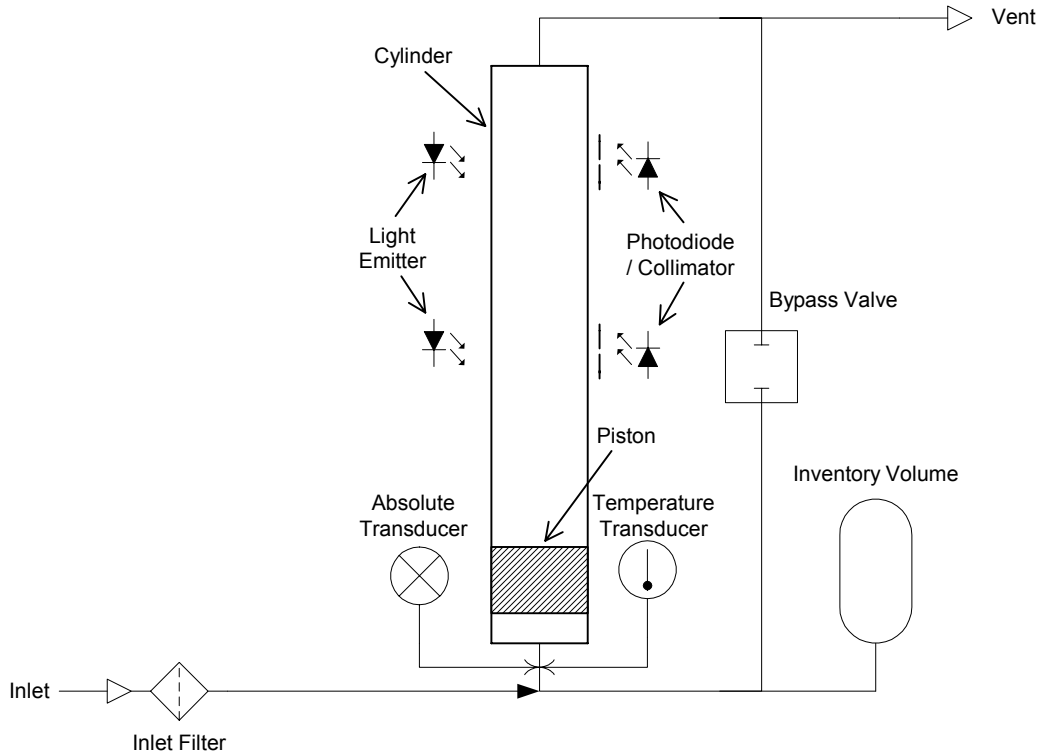

Figure 2 Practical Piston Prover

7.0 Operating Instructions

Charging the ML-350

For details on charging the ML-350, please see Section 10.1, Charging the ML-350.

Turning the ML-350 On

Press **On** to start the ML-350. An opening screen will appear indicating the instrument's revision level followed by the "Main Menu".

Turning the ML-350 Off

The ML-350 has a battery saving automatic shut off system. After 65 minutes of inactivity, the ML-350 will shut off. Alternatively, the unit can be shut off manually by pressing the **Print** button followed by the **Stop** button from the "Main Menu".

LCD Backlight

The ML-350's LCD display includes a backlight function to illuminate the display. The default setting for the backlight is always on. If you wish to conserve battery power you may wish to turn the backlight off or enable the backlight only when inputting information on the keypad.

To toggle the backlight on and off, enter "Setup Menu -1" and choose the third option. Please see Section 8.1, Option 3

Low Battery Indicator

A low battery condition is indicated by a “B” appearing in the upper right-hand corner of the LCD. The low battery indicator allows the user to connect to an external power source prior to the unit powering down. Time between low battery indication and loss of power varies depending on the current application.

7.1 ML-350 Keypad

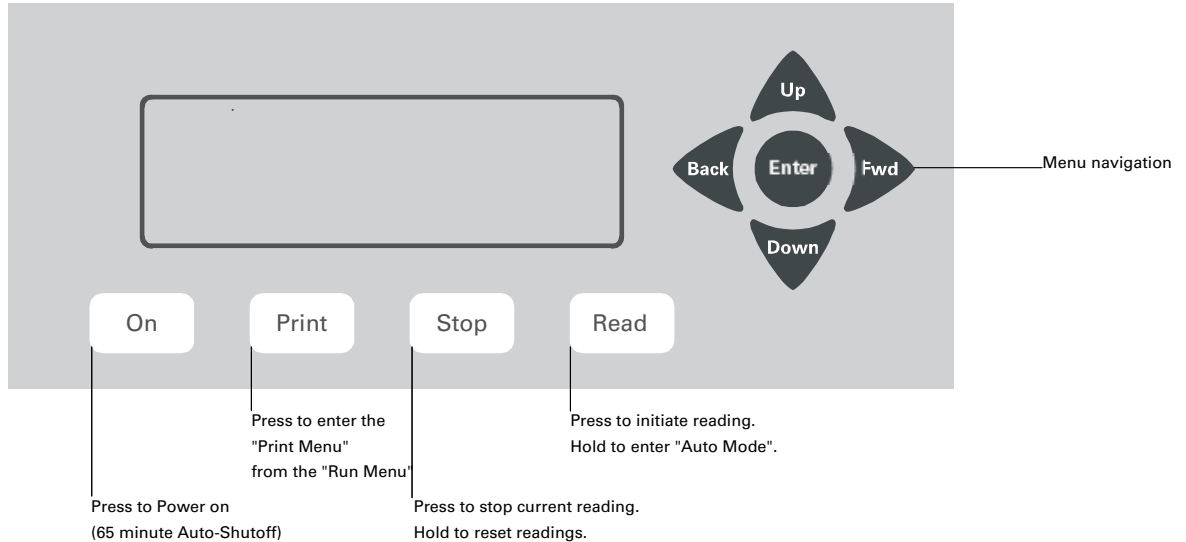

7.2 How To Use the ML-350 Keypad

General Menu Navigation

Use the **Up/Down** arrows to navigate between different lines within a menu. Use the **Enter** button to select a field to be modified and to lock-in any changes. Use the keypad for data entry, such as entering a User ID Number; use the **Up/Down** arrows to toggle between fields, such as Temperature or Pressure units. Use the **Fwd** and **Back** keys to advance to the following menu or return to the previous menu.

On Button

Powers the ML-350 on (65-minute auto shut-off).

Print Button

Enters the “Printer Menu” (must be accessed from the “Run Menu”). See Section 9.0, Printing.

Stop Button

Stops current reading and opens the valve, allowing the piston to return to its resting state. Holding the **Stop** button down for 2 seconds will reset the readings.

Read Button

Initiates a single reading (must be accessed from the “Run Menu”). Holding the **Read** button down for 2 seconds will initiate Auto Mode. Auto mode Initiates automatic readings (must be accessed from the “Run Menu”). If the Reading type has been set to “Cont” in “Setup Menu – 2”, the unit will run until the preset average is reached and then restart the cycle. If the Reading type has been set to “Burst” in “Setup Menu – 2”, the unit will run until the preset average is reached and then stop.

7.3 Factory Default Settings

The ML-350 has a number of user-definable features and settings. To return to factory default settings from the “Main Menu” at any time, press **Print** followed by the **Down** arrow.

Parameters	Factory Settings	Optional Settings
No. of Readings in an Averaging Sequence	10	1–100
Atmospheric Pressure	mm Hg	kPa, mBar, Psi
Temperature	°C	°F
Standardized Temperature Setting	0 °C	0.0–50.0 °C
Date Format	MT/DT/YR	DT/MT/YR
Time Format	AM/PM	24 Hr
Delimiter Setting	[,] comma (for RS-232 export)	no options
Control	Int. (internal)	Ext. (external)

7.4 Connecting the ML-350 to a Flow Source

 The accuracy of the DryCal is dependent upon its source being stable. An unstable flow source may produce inconsistent readings.

The DryCal ML-350 is designed to be used at ambient pressures. Do not subject the ML-350 to pressures above 0.35 bar (5 PSI).

To use a pressure flow source, connect the flow source to the inlet fitting. To use a vacuum flow source, connect the flow source to the outlet fitting. Use tubing appropriate to the inlet and outlet fittings that you have selected. In example, 1/4" tubing for the 1/4" fittings that come standard with the ML-350.

7.5 Taking Readings

The DryCal ML-350 default is preset for ten (10) readings in an averaging sequence. This parameter is user-definable (see Section 8.2 Setup Menu 2, Reading Type, # in Average & Minutes/Reading).

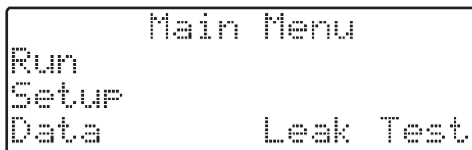

1 Press **Enter** or **Read** to enter the “Run Menu”.

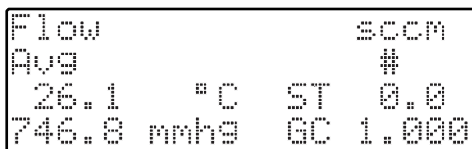

- Press the **Read** button to initiate a single reading.
- Hold the **Read** button to initiate multiple reading mode.
- Press the **Stop** button to stop current flow reading and open valve.
- Hold the **Stop** button to clear the display of current data.

8.0 Setting User Preferences

The DryCal ML-350 offers enhanced electronics options to allow the user to define parameters specific to an application. There are six Setup Menus.

General Menu Navigation

Use the **Up/Down** arrows to navigate between different lines within a menu. Use the **Enter** button to select a field to be modified and to lock-in any changes. Use the keypad for data entry, such as the number of readings in an averaging sequence; use the **Up/Down** arrows to toggle between fields, such as Temperature or Pressure units. Use the **Fwd** and **Back** keys to advance to the following menu or return to the previous menu.

```

Main Menu
Run
Setup
Data          Leak Test

```

To enter "Setup Menu – 1" from the "Main Menu", select Setup and press **Enter**.

8.1 Setup Menu 1, Calibration ID #, Gas Constant, Calibration Type

```

Setup Menu - 1
Gas Constant 1.000
Cal. Type    Std.
Backlight    On

```

Option 1, "Gas Constant"

This option changes the gas constant for the use of surrogate or proxy gasses. Proxy gas conversions vary by device manufacturer. Please see the instrument manufacturer's proxy gas conversion multipliers for the device under test. The input range for this option is 0.200–2.000. The default setting is for 1.000, the setting for air.

Option 2, "Cal. Type"

This option changes the sample type being displayed. Toggles between "std." (standardized readings) and "vol." (volumetric readings).

Option 3, "Backlight"

This option changes allows the backlight on the LCD to be turned on or off.

8.2 Setup Menu 2, Reading Type, # in Average & Minutes/Reading

```
Setup Menu - 2
Reading Type   Cont
# in Avg      10
Min/Reading   00
```

Option 1, "Reading Type"

Toggles between "Cont." (continuous auto-read) and "Burst" (performs continuous auto-read, then stops after the quantity in averaging sequence is reached [as programmed in Setup Menu 2, Option 2, # in Average]).

Option 2, "# in Average"

Changes the quantity in an averaging sequence (consecutive readings) from 1 to 100.

Option 3, "Min./Reading"

Specifies the time interval (in minutes) between flow readings.

8.3 Setup Menu 3, Temp. Correction Factor, Temp. & Pressure Formats

```
Setup Menu - 3
Pres Units    mmHg
Temp Units    °C
Temp Corr     0.0°C
```

Option 1, "Pres. Units"

This option allows you to toggle between mmHg, mBar, kPa and PSI.

Option 2, "Temp. Units"

This option allows you to set the temperature units for ° F or ° C.

Option 3, "Temp. Corr."

This option is used to set the standardization temperature.

8.4 Setup Menu 4, Date, Time & Battery Voltage

This menu has an alternate navigation method.

Within this menu, use the **Fwd** and **Back** arrows to select each option, such as Month or Day. To change a selected option, use the **Up** and **Down** arrows. Date and time formats are specified using Setup Menu 5, Date and Time Formats.

```
Setup Menu - 4
07/18/00      05:03 AM
Bat  6.98  Volts
```

Option 1, Date

This option allows you to set the date.

Option 2, Time

This option allows you to set the time.

8.5 Setup Menu 5, Date & Time Formats

```
Setup Menu - 5
Date - MT/DT/YR
Time - AM/PM
Auto off Enable
```

Option 1, "Date"

Toggles between "MT/DT/YR" and "DT/MT/YR" date format.

Option 2, "Time"

Toggles between "AM/PM" and "24 Hr" time format.

Option 3, "Auto Off"

Toggles between "Enable" or "Disable" 65-minute auto-shut off.

8.6 Setup Menu 6, Leakage & LCF (Leakage Correction Factor)

There is a very small gap between the piston and the interior of the glass flow cell, allowing a known volume of gas to leak past during calibrations. This is the underlying operating principal of the DryCal, allowing the elimination of fluid seals used in earlier piston prover designs.

At low flows, this fixed leakage becomes a greater percentage of the overall measurement uncertainty. The leakage rate of each individual flow cell is quantified at Bios' factory using nitrogen, and entered into the DryCal as the Leakage, to be factored into subsequent readings.

If your application requires a flow rate of less than 10% of the full scale of the specified range for your model and the gas being used is not nitrogen or air, LCF may be a concern. Please consult Bios for assistance.

```
Setup Menu - 6
Leakage 0.000
LCF      1.000
Control Int.
```

Option 1, "Leakage"

This is the Leakage rate of a particular unit. It is factored into the flow readings to obtain a leakage-independent flow reading. The Leakage is factory-set and non-adjustable.

Option 2, "LCF"

This is the Leakage Correction Factor, and is multiplied by the Leakage value to enhance accuracy at lower flows when using gases other than nitrogen. The LCF factory setting is 1.000, although it may be changed to any value between 0.200 and 3.00. For further information, please contact Bios.

Option 3, "Control"

Toggles between "Int." (internal) or "Ext." (external) control. Choose internal control for normal operation.

9.0 Printing

The DryCal ML-350 is not guaranteed compatible with printers except those supplied by Bios. The DryCal sends basic ASCII text in serial format to a printer.

Bios offers the BP-1 stand-alone battery powered printer for hard-copy output of DryCal data. This printer is small, portable, convenient and easy to use. It makes an excellent dedicated printer for use with DryCal products. Bios cannot guarantee compatibility with any other printer than the Bios BP-1 portable thermal printer.

Data can be "printed" through the serial port to the printer (see below) or to a computer using the DryCal Communications Program CD Rom included with your ML-350.

```
Flow          sccn
Avg           #
 26.1    °C   ST  0.0
746.8 mmHg  GC  1.000
```

Press the **Print** button from the "Run Menu" to enter the "Printer Menu".

9.1 ML-350 "Printer Menu"

```
Printer Menu
Printer Off
Headings On
Printer Mode 1
```

Printer

Turns the printer and RS-232 off or on.

Headings

Turns the Headings option off or on. Users interested in manipulating data in a spreadsheet program may prefer to turn headings off to eliminate superfluous data collection, such as date and time.

Printer Mode

Sets mode 1 or mode 2. Mode 1 is the standard print mode; Mode 2 will add a second carriage return/line feed to the print.

9.2 Printing "Real-Time" Data

Setting the print option to "On" sends data to the serial port. The print on/off function allows the user to have a continuously connected printer, but to output information to the printer only when "Print On" is chosen.

Plug the printer cable into the serial port located on the back of the ML-350. Make sure the ML-350 and the printer are on.

```
Flow          sccm
Avg           #
 26.1        °C   ST  0.0
746.8 mmHg   GC  1.000
```

- 1 Press the **Print** button from the “Run Menu” to enter the “Printer Menu”.

```
Printer Menu
Printer Off
Headings On
Printer Mode 1
```

- 2 Set Printer to “On”.
- 3 Choose Headings and Printer mode parameters.
- 4 Press **Forward** button to advance to the “Run Menu”.
- 5 Subsequent readings will print until “Printer” is set to “Off” on the “Printer Menu”.

10.0 Battery System

The DryCal ML-350 is powered by an internal lead-acid battery. The battery will power the instrument for 6–8 hours of continuous use and has a typical service life of approximately 2–4 years, depending on use. The ML-350 provides a convenient 65-minute automatic shut-off to extend battery life. Use of a printer does not affect battery life.

The ML-350 can be charged by the Bios-supplied charger when plugged into a standard 115V AV power source outlet (220V AC optional).

10.1 Charging the ML-350

Before using your calibrator, be sure that the battery system has been adequately charged to ensure that the ML-350 will perform to its specifications and maintain operation for the calibration period. If “B” is indicated in the upper right-hand corner of the display during operation, recharging is required.

Upon full charge, the charger will taper to a trickle mode automatically. The unit may be charged indefinitely without damage to the battery. Be sure to use only Bios-approved batteries and AC adapters/chargers for all DryCal flow calibrators.

- 1 Connect the Bios-supplied charger into a standard wall outlet.
- 2 Insert the DryCal charger’s barrel plug end into the charging jack located on the right side of the calibrator base. The green Charge LED will illuminate. Full charge takes 8 –12 hours, and the DryCal can charge while being used.

10.2 Battery Maintenance & Storage

Battery Maintenance

Lead-acid batteries will not exhibit the “memory effect” common to nickel-cadmium batteries due to continuous charging and no further conditioning is required to maintain full performance.

Long-Term Storage

Long-term storage without charging can damage the battery pack. If the DryCal cannot be left charging continuously, it should be fully charged at least once every three months.

11.0 Maintenance, Quality Assurance

Although the DryCal ML-350 is a rugged instrument, certain care and maintenance requirements must still be met. When not in use always store your ML-350 in a clean, dry environment. When possible leave the unit on charge. Wipe only with a damp cloth and do not spray with liquid solvents or use abrasive cleaners.

Any service to the DryCal ML-350 must be performed by Bios maintenance personnel.

Current service and calibration information and pricing can be found at www.drycal.com/service/ML-350.htm

11.1 Leak Test Procedure

A quality assurance self-test feature is provided to verify proper integrity of the unit. It is recommended that the self-check leakage test be conducted periodically as part of an ongoing quality assurance program. Passing the leak test does not ensure proper function of the ML-350. It does ensure that total leakage is within the product's allowable limits. To ensure proper function of the ML-350 annual factory calibration is recommended. The leak test may take as long as 6 hours or more, per fitting, to complete.

Since the leak test may take several hours per fitting, it is recommended to plug the charger into the base during the leak test to prevent the unit from turning off.

To Initiate the Leak Test

- 1 Place the ML-350 on a flat, vibration-free surface.

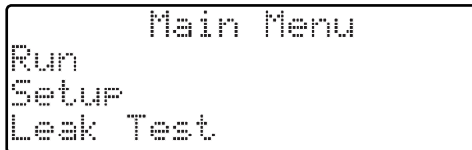

```
Main Menu
Run
Setup
Leak Test
```

- 2 From the "Main Menu" select "Leak Test".
- 3 After a leak test is initiated, the display will read:

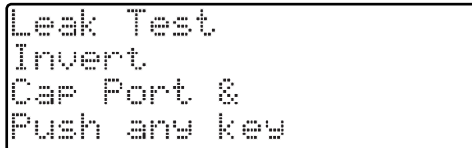

```
Leak Test
Invert
Cap Port &
Push any key
```

- 4 Cap the inlet or outlet port and invert unit.
- 5 Push any key while inverted.
- 6 Set unit upright. The display will read:

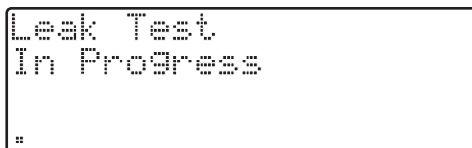

```
Leak Test
In Progress
*
```

- 7A If the test is completed successfully, the display will read:

```
Leakage
0.020 ccm
Push any key
```

7B If the unit fails the leak test, the display will appear similar to the following picture. Please make a note of the number that is displayed and contact Bios customer service.

```
Leakage
> 9.999 ccm
Push any key
```

8 Repeat the procedure with the leak test port cap over the opposite port fitting.

11.2 Calibration

As a quality assurance measure, Bios recommends annual calibration of all measurement instruments. However, how often you have your DryCal calibrated is an internal quality control decision. The determining factors are whether the unit passes the internal leak test, quality system requirements if applicable, and the conditions in which the unit is used. Units used in a laboratory setting may require calibration less frequently than a unit that is used in a manufacturing environment. The annual calibration program is an elective and is therefore not included as a warranty item. Expedited “48 hour” turnaround service is also available at an additional cost. Please contact Bios for more information on available calibration services and pricing.

Calibration Includes

- Cleaning (if required)
- Valve adjustment (if required)
- Battery capacity test
- Internal computer program upgrade as necessary
- Mechanical upgrades as necessary
- Run-in test
- Dynamic performance test
- NIST-traceable calibration certificate

11.3 Returning Your Unit for Calibration or Service

Prior to returning your DryCal for service or calibration, please contact Bios International for an RMA number. You can telephone Bios at (800) 663 4977 or (973) 492 8400, email service@drycal.com, or request an RMA via our website www.drycal.com.

11.4 Shipment

When shipping the DryCal ML-350 please ensure that the packaging is adequate to protect the instrument. When possible the ML-350 should be shipped in its original packaging. Bios International is not responsible for damage that occurs during shipment.

When transporting by air, the internal solenoid valve must be in the “open” position to avoid possible damage to the instrument. To open the valve, from the “Run Menu” press the **Stop** button. The valve position may be verified by sealing both the inlet and the outlet fitting. The piston should move freely up and down within the cylinder.

11.5 Replacement Parts & Accessories

Part	Description
PEL-1450	Pelican case with foam insert, fits 1 ML-350 unit
PEL-1450-F	Replacement foam insert for PEL-1450
PEL-1600	Pelican case with foam insert, fits 2 ML-350 units
PEL-1600-F	Replacement foam insert for PEL-1600
PEL-1610	Pelican case with foam insert, fits 3 ML-350 units
PEL-1610-F	Replacement foam insert for PEL-1610
SB-ES7	Padded soft shoulder bag w/detachable shoulder strap & accessory compartment
BP-1	4" wide battery-powered stand-alone printer, 120V** AC adapter, cable & printer paper
BAT-350	Battery, 6V lead-acid, for ML-350
BC12-120	120V charger
BC12-240	240V charger
BC12-UNI	Battery charger; 120/240V; Please specify country(ies) of use
BC-UNI-PLUG	Additional plug configurations (for universal AC adapter), each
SL-F-0.25	Swagelok [®] ferrule, please specify size
SL-P-0.25	Swagelok [®] leak test plug, please specify size
SL-SNOOP	Swagelok [®] Snoop for leak detection, 8 oz.
SL-MLU-0.25	1/4" Swagelok [®] fitting; one set
SL-MLU-0.375	3/8 " Swagelok [®] fitting; one set
SL-MLU-0.50	1/2" Swagelok [®] fitting; one set
SL-TA-0.25	1/4" barbed tube fitting
SL-TA-0.375	3/8 " barbed tube fitting
SL-TA-0.50	1/2" barbed tube fitting
CA-LT	Leak test cable
BAT-414	Printer battery
BC-DPU414-120	120V, 6.5 VDC AC adapter for printer
BC-DPU414-240	240V, 6.5 VDC AC adapter for printer
TP-2	Thermal printer paper, 1 roll, 4"
CA-22	Printer cable

*If you require a 240V charger for your printer, please specify. An additional charge will be added to your bill for the substitution.

12.0 Limited Warranty

The Bios DryCal ML-350 is warranted to the original end user to be free from defects in materials and workmanship under normal use and service for a period of 1 year from the date of purchase as shown on the purchaser's receipt. The ML-350's battery is warranted for 6 months from the original purchase date. If the unit was purchased from an authorized reseller a copy of an invoice or packing slip showing the date of purchase may be required to obtain warranty service.

The obligation of Bios International Corporation under this warranty shall be limited to repair or replacement (at our option), during the warranty period, of any part which proves defective in material or workmanship under normal use and service provided the product is returned to Bios International Corporation, transportation charges prepaid.

Notwithstanding the foregoing, Bios International Corporation shall have no liability to repair or replace any Bios International Corporation product:

- 1** Which has been damaged following sale, including but not limited to damage resulting from improper electrical voltages or currents, defacement, misuse, abuse, neglect, accident, fire, flood, act of God or use in violation of the instructions furnished by Bios International Corporation,
- 2** Where the serial number has been altered or removed or
- 3** Which has been repaired, altered or maintained by any person or party other than Bios International Corporation's own service facility or a Bios-authorized service center.

This warranty is in lieu of all other warranties, and all other obligations or liabilities arising as a result of any defect or deficiency of the product, whether in contract or in tort or otherwise. All other warranties, expressed or implied, including any implied warranties of Merchantability and fitness for a particular purpose, are specifically excluded. In no event shall we be liable for any special, incidental or consequential damages for breach of this or any other warranty, express or implied, whatsoever.

Appendix A: ML-350 Trouble-Shooting Guide

A-1.0 Unit does not turn on

Battery may be deeply discharged or dead.

- 1 Plug charger into unit
- 2 Confirm that the **Charge** LED is lit
- 3 Wait 10 minutes and try turning unit on again.
- 4 If the unit still does not work, please contact Bios.

A-2.0 Unit suddenly turns off

Battery may not be fully charged.

- 1 Plug charger into unit.
- 2 Turn on the ML-350.
- 3 Enter "Setup Menu – 4" to check battery voltage.
- 4 Battery voltage should be 6.00 volts or higher.

A-3.0 "B" appears in the upper right corner of the Run screen

Battery is getting low and should be recharged.

A-4.0 The Charge LED does not light when charger is plugged in

- 1 Is the wall outlet working properly?
- 2 Are you using the correct charger? Please be sure to be using a Bios 12V charger
- 3 Is the charger working properly? If possible, measure the voltage with a voltmeter. The voltage should be greater than 12 volts.

A-5.0 Settings have been lost or seem to have changed

If the battery is removed or allowed to discharge your settings may be lost. Reprogram instrument to desired settings. See Section 8.0, Setting User Preferences.

A-6.0 Printer does not print

- Is the printer connected to the ML-350?
- Is the printer turned on and online?
- Is the printer "On" under the ML-350 "Printer Menu"? See Section 9.1, "ML-350 Printer Menu".
- The printer may not be compatible with the ML-350. Use of Bios BP-1 Thermal Printer is recommended.

A-7.0 “Piston Error” appears on display

This error message could be caused by any of the following:

- 1A** The piston is not reaching the cell-bottom within the time allotted by the program.
 - Push any key to return to the Read Screen.
 - If you want the ML-350 to start taking readings again, press **Read** or **Auto**.
- 1B** The piston does not return to the cell bottom at all.
 - The flow rate may be too high for the model being used; make sure that the flow is within the model’s specified range.

A-8.0 The piston does not move when “Read” or “Auto” is pushed

- 1** Is a flow source connected?
- 2** Is the flow source connected correctly (Pressure vs. Vacuum)?
- 3** Is the flow source inadvertently set too low?
- 4** Are any of the ports sealed?
- 5** Are any of the tubes pinched?
- 6** Are any of the connections loose or leaking? Swagelok® fittings leak if they are not tightened properly.
- 7** Can you hear the valve working? If not, contact Bios.

A-9.0 When taking readings, the flow appears to be inaccurate

- 1** Are any of the connections loose or leaking? Swagelok® fittings leak if they are not tightened properly
- 2** Are any of the tubes pinched?
- 3** Is the gas constant set to the correct number? See Section 8.1, Setup Menu 1, Calibration ID #, Gas Constant, Calibration Type.
- 4** If you are using the units within the lower 10% of its flow rating and with a gas other than air, check to make sure the LCF (Leakage Correction Factor) is set correctly. See Section 8.6, Setup Menu 6, Leakage & LCF.

A-10.0 Readings taken with the ML-350 do not correlate to those taken with another flow meter

Please see Section A-9. If this does not solve your problem, please check the following:

- 1** Are you comparing volumetric flow with standardized flow? See Section 8.1, Setup Menu 1, Calibration ID #, Gas Constant, Calibration Type.
- 2** If both units are set to “Standardized”, are both units set to the same standardized conditions? See Section 8.3, Setup Menu 3, Temp. Correction Factor, Temp. & Pressure Formats.
- 3** Are there any large containers in the flow stream, such as extra tubing, large damper(s), Magnehelic gauges, etc.? These items can cause inaccurate readings.
- 4** Is the flow source strong enough that it will not be affected by small variants of back pressure?

A-11.0 During Leak Test, “Leakage > 9.999 ccm” appears on display

- 1 Check for poor connections on either the pressure or suction port.
- 2 Make sure all fittings are tight.

A-12.0 The ML-350 does not appear to be sending data through the serial (RS-232) port

- 1 Is the serial cable plugged into the correct COM port and the ML-350? The default COM Port for the DryCal Communications Program is COM1. Please refer to the *DryCal Communication Program Installation Instructions*, Section 3.0 for information regarding changing the COM Port.
- 2 Is the cable OK? The cable should be a 1 to 1 connection, not a null modem cable.

A-13.0 Resetting the ML-350

Operational Reset

There is a **Reset** button recessed in the back of the ML-350. Use the **Reset** button in order to override current operation and force a restart of the ML-350. All settings will be retained, although current flow data will be lost.

Reloading Default Settings

To return the ML-350 to factory default settings for Number of Readings in an Averaging Sequence, Atmospheric Pressure, Temperature, Standardized Temperature Setting, Date Format, Time Format, and Delimiter Settings, press **Reset** followed by **Save**. “Resetting” will appear on the LCD indicating that the unit has returned to factory default settings. Remember to set current date and time (see Section 8.4, Setup Menu 4, Date, Time & Battery Voltage).

Bios International Corporation

10 Park Place

Butler, New Jersey, USA 07405

Phone (973) 492 8400

Toll Free (800) 663 4977

Fax (973) 492 8270

Email sales@drycal.com

Web www.drycal.com



© 2005 Bios International Corporation

MK01-21 A