

OPERATING INSTRUCTIONS

AIR SAMPLING PUMPS

MODELS:

AirPro® MET-ND

AirPro® MET-LB



BIOS INTERNATIONAL CORPORATION

TABLE OF CONTENTS

<i>Section</i>	<i>Description</i>	<i>Page</i>
1.0	INTRODUCTION	4
1.1	Safety Precautions	4
1.2	Unpacking Checklist	5
1.3	General Description	5
1.4	Power Requirements	5
1.5	Product Specifications	6
1.6	Options	6
1.7	Warranty Information	7
1.8	Customer Service and Technical Support	7
1.9	Features	8
	<i>Figure 1-A, PUMP FEATURES</i>	9
	<i>Figure 1-B, LCD DATA DISPLAY</i>	10
2.0	SET-UP AND PREPARATION.....	11
3.0	THEORY OF OPERATION.....	11
4.0	OPERATING INSTRUCTIONS.....	12
4.1	Charging the Battery System	12
4.2	Battery Maintenance and Storage	12
4.3	Turning Power "ON"	13
4.4	Starting the Sampler	13
4.5	Pausing the Sampler While Running	13
4.6	Turning Power "OFF"	13
4.8	Setting the Flow Rate (High Flow non-programmed)	14
4.8	Setting the Flow Rate (High Flow programmed)	14
4.9	Calibrating the Set Flow Rate (High Flow)	12
4.10	Calibrating the Set Flow Rate (High Flow)	12
	<i>Figure 4-A, HIGH FLOW CALIBRATION SETUP</i>	16
	Calibrating the Set Flow Rate (High Flow), cont'd	14
4.11	Programming Time Functions	15
	4.9.1 Clearing "Accumulated Time" Function	17
	4.9.2 Setting the "Run Time" Function	17
	4.9.3 Setting the "Delay Start Time" Function	18
4.12	Entering Constant Pressure Mode (Low Flow)	17
4.13	Low Flow & Multi-Flow Pump Calibration	19
	<i>Figure 4-B, LOW FLOW CALIBRATION SETUP</i>	20
4.14	Anti-Tamper Plate	21
4.15	Electronics Revision Level	21

<i>Section</i>	<i>Description</i>	<i>Page</i>
5.0 TROUBLESHOOTING		22
5.1	Display Messages, Errors, Faults	22
5.2	Unit Displays “Hi P” Message (Pressure Fault)	22
5.3	Unit Displays “BAT” Message (Battery Low)	23
5.4	Pump Will Not Turn On and Display Not Indicating	23
5.5	Pump Shuts Off When Attempting Calibration	23
5.6	Pump Does Not Run In Sample Mode	23
5.7	Red Battery LED Indicates “Charging” and Sampler Does not Turn “On” or “Run”	23
5.8	Sampler Does Not Perform Eight Hours of Sampling	24
5.9	“Charging” LED Does Not Illuminate	24
5.10	Sampler Runs Full-Out Without Any Flow Control	24
5.11	Sampler Giving Incorrect Flow as Compared to Calibrator	25
6.0 TECHNICAL REPAIRS AND SERVICE		26
	Figure 6-A, PUMP DISASSEMBLY OVERVIEW	26
6.1	Case Disassembly Procedure	27
6.2	Removing the Battery Pack Assembly	28
6.3	Removing the Pump/Motor and Damper/Filter Assemblies	29
6.4	Removing PC Electronics Board Assembly	30
6.5	Reinstalling PC Board Assembly	30
6.6	Cleaning/ Replacing the Damper Filter Screen	31
7.0 MAINTENANCE/ STORAGE/ SHIPMENT		32
8.0 PARTS LIST		33
9.0 GLOSSARY OF COMMON AIR SAMPLING TERMS		34-35
QUICK-START CARD TEMPLATE		37

1.0 INTRODUCTION

Congratulations! You have purchased a high-quality product from BIOS International Corporation. BIOS develops useful technologies that aid the industrial hygienist to sample for personal and environmental chemical hazards. The performance features found in the BIOS line of personal air samplers and sampling equipment offer convenience, versatility and the assurance of valid sampling data. From sampling pumps to calibrators, BIOS provides a complete range of products for sampling dust, asbestos, metals, gases and vapors. This manual contains operation and maintenance information for the BIOS AirPro Metalite ND and LB Personal Air Samplers.

1.1 SAFETY PRECAUTIONS



Please read all warnings and instructions indicated in this manual before operating equipment or plugging into an electrical outlet. Failure to do so may cause permanent damage to the equipment, personal injury or void warranty rights. Retain all operational documentation for future reference.



The BIOS AirPro Metalite ND & LB samplers employ rechargeable batteries. Operation and recharging of this battery system should be accomplished in accordance with the sampler or charger labeling, with the appropriate BIOS wall-mounted or multi-station charger. Use of this equipment for purposes other than indicated in this manual or on product labeling, may cause personal injury and will void any warranty rights to the user, owner or personnel associated with the use of this product. Do not operate any BIOS equipment in excessive chemical or water vapor atmospheres. Failure to follow instructions may cause permanent damage to equipment. Do not service this product yourself unless you are a certified BIOS Repair Service Technician in compliance with BIOS standards and procedures. Servicing your unit may void all warranties and rights. Please contact a BIOS Customer Service Representative at (800) 663-4977 to schedule any technical repairs.

1.2 UNPACKING CHECKLIST

Your quality BIOS product has been packaged with care and includes all components necessary for full operation. Please take a moment to check that you have received the following items. If you believe you have not received a full shipment or if you have any questions, please contact your customer service representative immediately.

- Metalite ND or LB Personal Air Sampler
- Single-Station Battery Charger, (Single-pump kits),
5-Station Charger, (5-pack kits)
- Tubing, Bag Sampling Adapter Accessory
- Low flow/Constant Pressure Bleed Adapter Accessory
- Carrying Case, (Multi-Pump Kits Only)
- Quick-Start Instruction Card
- Instruction Manual, Warranty Card

1.3 GENERAL DESCRIPTION:

The AirPro Metalite ND/LB Personal Air Samplers are compact, portable instruments for collection of dust, asbestos, metals, gases and vapors. Samplers are deployed in abatement, industrial, environmental hygiene and laboratory programs utilizing standard filter cassettes and sorbent tubes. The samplers consist of a pneumatic system, a control system, and a rechargeable battery system, all housed in a sturdy case. Built-in constant flow, constant pressure, low flow modes, programmable timing functions and digital anti-tamper lock are standard features. The constant pressure, single and multi-sample capabilities are utilized in conjunction with a variable orifice accessory and flows are adjusted via needle valves.

Models: AirPro Metalite ND Personal Air Sampler
 AirPro Metalite LB Personal Air Sampler

1.4 POWER REQUIREMENTS

The AirPro Metalite ND and LB Personal Air Samplers are charged and/or can be powered by the BIOS single-station or a five-station AC Battery charger when plugged into a standard 115V AC power source outlet (220VAC optional). Please read all setup and charging instructions indicated in this manual before using equipment.

1.5 PRODUCT SPECIFICATIONS :

	<u>Model Metalite ND</u>	<u>Model Metalite LB</u>
Size:	4.6" x 3.7" x 2.3" / 116mm x 95mm x 59mm	
Weight:	26 oz./ 737 g	34 oz./ 966g
Dynamic Range:	1 to 4000 ml/min.	5 to 6000 ml/min.
Constant High Flow:	750 to 5000 ml/min.	1000 to 6000 ml/min.
Constant Pressure:	1 to 1000 ml/min.	5 to 2500 ml/min.
Flow Capacity: (8-hour use)	<u>ml/min. @ in./H2O</u> 5000 nominal max 4000 @ 9" 3000 @ 23" 2000 @ 30" 1000 @ 30"	<u>ml/min. @ in./H2O</u> 6000 @ 10" 5000 @ 18" 4000 @ 25" <3500 @ 30"
Filter Rating:	2.6 Lpm Max. flow for 8-hour use with .8m, 25mm cassette.	3.8 Lpm
Battery System:	6V NiCad Pack	12V Lead Acid Battery
	Rechargeable 8-hour operation. Can be run while charging without damage to battery. Both batteries are UL approved.	
AC Battery Charger:	Wall-mounted, single-station or five-station charger.	
Electronics:	LCD time/function display, programmable timer, functions, anti-tamper lock. Maintains user programming in memory, Auto-prompt programming and set-up functions with Program, Set, Adjust, Run, Pause, Delay, Constant Pressure Mode, and Calibration functions. Charging LED indicator.	
Case:	Stainless Steel with intrinsic RFI/ EMI shielding, water resistant, integral belt clip	
UL Approvals:	BIOS AirPro Metalite ND & LB Personal Air Samplers and BIOS battery packs are UL approved intrinsically safe for use in hazardous locations class I, groups A, B, C, D, class II, groups E, F, G and class III. UL Listed 87Y4, Temperature Code T3C.	

1.6 OPTIONS

You may purchase additional calibration and support items from BIOS for this system. Please refer to the BIOS Metalite ND/LB Spare Parts List or the full BIOS International Corporation product line catalog. If you should require additional assistance, please contact your customer service representative at (800) 663-4977.

1.7 WARRANTY INFORMATION

BIOS equipment is warranted to the original end user to be free from defects in materials and workmanship under normal use and service for a period of one year from the date of purchase as shown on the purchaser's receipt.

The obligation of BIOS International Corporation under this warranty shall be limited to repair or replacement (at our option), during the warranty period, of any part which proves defective in material or workmanship under normal use and service provided the product is returned to BIOS International Corporation, transportation charges prepaid.

Notwithstanding the foregoing, BIOS International Corporation shall have no liability to repair or replace any BIOS International Corporation product (1) which has been damaged following sale, including but not limited to damage resulting from improper electrical voltages, defacement, misuse, abuse, neglect, accident, fire, flood, act of God or use in violation of the instructions furnished by BIOS International Corporation, (2) the serial number has been altered or removed or (3) which has been repaired, altered or maintained by any person or party other than BIOS International Corporation's own service facility or a BIOS authorized service center.

This warranty is in lieu of all other warranties, and all other obligations or liabilities arising as a result of any defect or deficiency of the product, whether in contract or in tort or otherwise all other warranties, expressed or implied, including any implied warranties of merchantability and fitness for a particular purpose, are specifically excluded.

In no event shall we be liable for any special, incidental or consequential damages for breach of this or any other warranty, expressed or implied, whatsoever.

1.8 CUSTOMER SERVICE AND TECHNICAL SUPPORT

Use this comprehensive operation guide for useful descriptions of product applications, procedures and safety precautions. If you require additional assistance, BIOS International Corporation offers complete technical support for all of its products. Customer service representatives are available Monday through Friday, 9:00 AM to 5:00 PM EST, (800) 663-4977.

1.9 FEATURES/ AirPro Models

Metalite ND and LB:

(Refer to Figure 1-A)

TOUCH PAD PROGRAMMING

Smooth, clean keypad design clearly shows program functions.

LCD DISPLAY

Multifunction, easy-to-read, digital program, flow set and readout, programmable timing range up to 99 hours: 59 minutes. Continuous run capability.

DATA RETENTION

EE ROM secures sampling data with or without power for indefinite time period or until cleared.

PROGRAMMABLE FUNCTIONS

Easily settable flow, delay and run periods set in hours and minutes, pause and constant pressure modes, high and low flow calibration, auto-prompt functions.

SELF-PROMPTING ELECTRONICS SETUP

Easy program and operation procedures advance at user input.

ANTI-TAMPER PLATE

Prevents programming and electronics from inadvertent tampering.

CONSTANT HIGH FLOW SAMPLING

For filter cassette and high flow sampling applications.

BUILT-IN CONSTANT PRESSURE MODE FOR MULTI-FLOW SAMPLING

The constant pressure, single and multi-sample capability is utilized in conjunction with a variable orifice manifold accessory. Flow is adjusted via the needle valve. Flow range: (ND) 1-1000 ml/min., (LB) 5-2500 ml/min.

RECHARGEABLE BATTERY PACKS

UL approved rechargeable battery pack systems, full capacity operation.

BATTERY CHARGE LED INDICATORS

“Charging” LED indicates unit is charging.

BUILT-IN BATTERY CONDITIONING CIRCUITRY

Electronics ensure protection against over-discharging of battery system. Automatic "Trickle" charge protects battery.

CONTINUOUS-RUN AC CAPABILITY

AirPro samplers can be run off 120/220VAC power continuously, with a single or multi-station BIOS battery charger.

WATER-RESISTANT CASE

Provides rugged, field protection to operational components. Intrinsic EMI/RFI resistance. Ergonomic design maintains smooth, projection-free styling.

RECESSED AIR-INLET HOUSING

Case design protects air inlet boss from any possible breakage.

SELF-CLEANING VALVES

No routine filter changes necessary.

INTEGRAL BELT CLIP

Secures sampler to belt of worker.

FIGURE 1-A
PUMP FEATURES & NOMENCLATURE

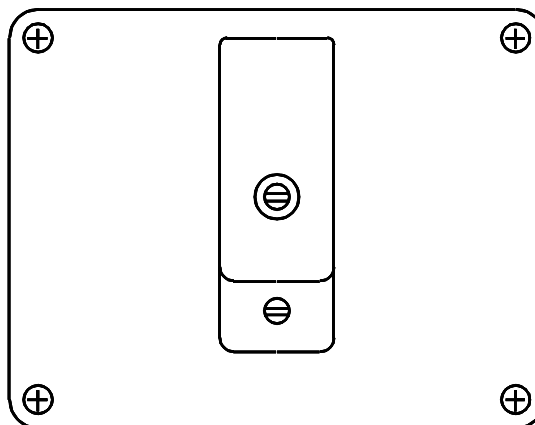
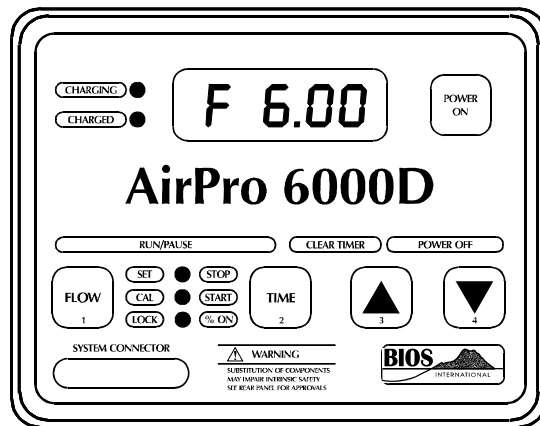
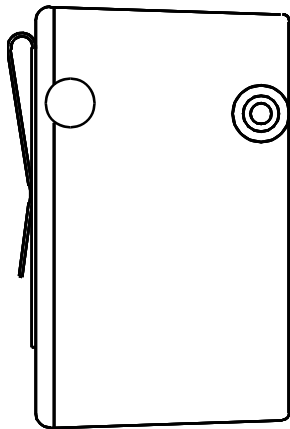
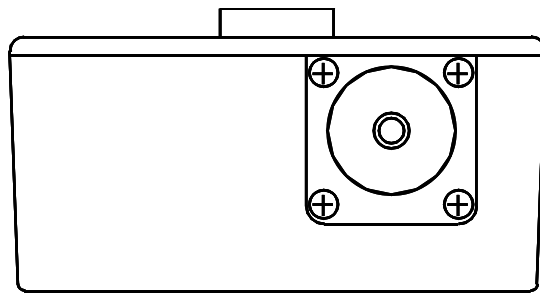

FIGURE 1-B

LCD DATA DISPLAY/ SAMPLES

1) Flow Rate, (Lpm)

2) Run Time & Cumulative Time, (Hr: Min.)

3) Total Volume, (Total Liters)

4) Calibrate Flow

Constant Flow

Mode Indicator

(Set Point, Lpm)

5) Delay Time, (Hr: Min.)

6) Low Battery Indicator

7) Constant Pressure Mode Indicator.

NOTE: Display is constant.

*Does not indicate changing
flow- rate. Flow is indicated
on calibrator display.*

8) Calibrate Flow

Constant Pressure

Mode Indicator

NOTE: Display is constant.

*Does not indicate changing
flow rate. Flow is indicated
on calibrator display.*

2.0 SETUP AND PREPARATION

By now you have unpacked your equipment and taken an inventory of the contents. You should now become familiar with your equipment by reading this instruction manual and practicing the operation of its functions. This will ensure that the product is working to performance specifications. Do this in a well-lit area on a stable, flat work surface free of any moisture, dirt or chemicals. A soft cloth or surface will preserve and protect the equipment. Be sure to fully charge the sampler according to the instructions and labeling. Refer to “Battery Maintenance” section for appropriate Battery Charging and Storage schedule information. If any accessories or optional equipment need to be installed, be sure to review all instructions for their proper use to avoid any personal injury, breakage, or damage to the equipment. When you are finished with equipment, remove all charging accessories and be sure to turn the power “OFF”. Repack appropriately for future use. Storage of equipment in a dry, clean and cool environment will extend product life and ensure future deployment.

3.0 THEORY OF OPERATION

The object of using a pump that maintains constant flow is very important. The AirPro Metalite ND/LB Personal Air Sampler draws air (suction side) through the sampling media. As the media collects the sample from the air, the more restricted the media becomes. The AirPro sampler will compensate by running the pump at greater speeds so that constant flow is maintained. If the flow is maintained at a constant flow and the time the sampler ran is measured along with that flow, the actual volume of air that passed through the sampling media is known; (i.e.: 4 Lpm for 120 mins. = 480 liters).

If the pump cannot maintain this constant flow rate because of a problem, (i.e.: clogged filter, pinched tubing, low battery, etc.) the sampler will display a fault condition. If the problem is not corrected within a specified period of time, the AirPro Metalite ND/LB sampler will shut off.

The constant pressure mode works in a similar manner. The object of the sampler is to keep a constant pressure across a given restriction. The use of the BIOS Air Bleed accessory, (Refer to “Figure 1-A, Pump Features”), prevents the pump from running at too low a speed. By varying the adjustment on the restriction (variable orifice manifold accessory), the flow can be adjusted and maintained at a constant flow, independently set. *NOTE: Flow rate data cannot be viewed directly from the display while in the constant pressure mode.*

4.0 OPERATING INSTRUCTIONS

In this section, you will be operating the Metalite ND/LB Personal Air Sampler. By pressing keys on the touch pad located on the front of the sampler, different functions will be accessed. When a button or LED is called out, it will be in quotes, i.e. "Charging". When you are to press specific keys, it is in brackets: i.e. <POWER-ON>.

CAUTION: *If you are unfamiliar with any of these keys or functions, please refer to "Figure 1-A, PUMP FEATURES" to familiarize yourself with all sampler features before continuing.*

4.1 CHARGING THE BATTERY SYSTEM:

Before you begin using your sampler, be sure that the battery system has a full charge to ensure that it will perform to its specifications and maintain operation for the required sampling period. If "LO BAT" or "BAT" is indicated on the display, recharging is recommended.

1. Connect the appropriate AirPro charger into a standard wall outlet.
2. Insert the charger's barrel plug end into the charging jack located on the left side of the AirPro sampler. The Red "CHARGING" LED will illuminate on the front of the sampler.
3. The unit will be completely charged in @ 8 hours. Remove the wall charger and place in appropriate storage for future use.

NOTE: *We strongly recommend not leaving the unit charging for more than 24 hours without running.*

4. The sampler is now fully charged.

NOTE: *To maintain intrinsic safety integrity, use only BIOS batteries and replacement parts approved for AirPro Metalite ND & LB Samplers.*

4.2 BATTERY MAINTENANCE AND STORAGE.

Battery Maintenance:

1. The battery can be charged indefinitely. The charging circuit in the sampler's electronics will automatically go to a trickle charge to prevent overcharging and any possible damage to the battery pack. *We strongly recommend not leaving the unit charging for more than 24 hours without running.*

Pump Storage:

2. If the sampler is not going to be used on a regular basis or left charging indefinitely, the battery pack should be charged to the full condition every 6 months and stored at room temperature.

4.3 TURNING THE POWER ON:

1. Activate the unit by pushing the <POWER ON> key located on the face of the sampler, at the top right-hand corner. The sampler is now ON and in the RUN state.
2. The unit will display the current Run Time "00:00", (i.e. 22:34) in hours and minutes.

NOTE: *If necessary, make note of the previous sample Run Time and clear it. If Cumulated Run time is not cleared, it will continue to accumulate with the next sample.*

4.4 STARTING THE SAMPLER:

1. To start sampler, push keys: <ON>. The pump will begin running in the non-programmable mode. The sampler can run continuously in this state until you turn the power push and hold <RUN/PAUSE> or turn the unit OFF. When sampling in a continuous-run state, it is recommended that you use the single-station charger to power the sampler.

NOTE: *If a delay has been programmed, the pump will start running when the Delay time reaches zero (00). Also, the clock will count for a maximum of 99:59 and then roll over and begin counting at zero again. You cannot set flow while in the RUN MODE. See section 4.7, SETTING THE FLOW RATE.*

4.5 PAUSING THE SAMPLER WHILE RUNNING:

1. To pause the pump while running;
2. Press and hold: <RUN/PAUSE> key until the pump stops running.
3. To resume sampling;
4. Press and hold: <RUN/PAUSE> key until the pump starts running.

NOTE: *The PAUSE state of the sampler can be used to program any of the timing functions individually. After two (2) hours of inactivity, the sampler will automatically POWER OFF and the display will blank.*

4.6 TURNING POWER "OFF" :

1. To turn sampler power "OFF",
Press: <▲> and <▼> keys simultaneously.
The display will blank. The sampler is now turned "OFF".

NOTE: *This function cannot be performed while the sampler is in the programming state. You must exit the programming state first before turning the sampler POWER "OFF". The sampler must be running or in the Pause state to manually turn the power off. See section "4.9, Programming Time functions".*

4.7 SETTING THE FLOW RATE (HIGH FLOW NON-PROGRAMMED) :

To set the samplers flow rate for high flow, be sure to connect the sampling media in-line for accurate flow and back pressure performance.

Equipment required: AirPro Metalite ND/LB Personal Air Sampler, tubing, sampling media (filter cassette), and BIOS DryCal® or other calibrator.

1. With POWER-ON, press and hold:
<RUN/PAUSE> key until the pump starts running.
2. Press keys <▲> or <▼> to Increase or Decrease the flow rate desired.
3. Flow is indicated on the calibrator in Lpm.
4. When the desired flow rate is reached, disconnect the calibrator. You can PAUSE the sampler and reset the Cumulative Time if desired.

4.8 SETTING THE FLOW RATE (HIGH FLOW PROGRAMMED) :

To set the samplers flow rate for high flow, be sure to connect the sampling media in-line for accurate flow and back pressure performance.

Equipment required: AirPro Metalite ND/LB Personal Air Sampler, tubing, sampling media (filter cassette), and BIOS DryCal® or other calibrator.

1. With POWER-ON and Sampler in Pause
Press and hold: <PROGRAM MODE> key until the pump displays “CAL” and the “SET”
2. LED illuminates. Release key.
3. Press keys <▲> or <▼> to Increase or Decrease the set flow rate required. Flow is indicated on the sampler in Lpm.

NOTE: Pressing and holding the <▲> or <▼> keys will increase selection speed.

1. When the desired flow rate is displayed, Press the <PROGRAM MODE> key once, the "ADJ" LED illuminates and the pump will begin running. The display indicates the flow rate selected with a “C” prefix. At this time, you may calibrate the sampler or press the <PROGRAM MODE> key twice to return to the PAUSE state.

4.9 CALIBRATING THE SET FLOW RATE (HIGH FLOW) :

(Refer to "FIGURE 4-A, HIGH FLOW CALIBRATION SETUP")

When setting high flows with media in-line, a flow calibrator will be necessary to verify the flow rate while sampling media is in-line.

Required Equipment: AirPro Metalite ND/LB Personal Air Sampler, BIOS DryCal Calibrator or other calibration device, tubing, sampling media (i.e. filter cassette, sorbent tubes).

Prior to performing High Flow calibration adjustment:

1. Confirm that the sampler is turned ON and the display indicates the flow rate you are using, i.e. "C 2.00". Also, be sure that the filter media being used is in-line for actual flow/ and back pressure performance calibration.
2. Confirm that the calibrator is turned "ON" and in-line per Figure 4-A, HIGH FLOW CALIBRATION SET-UP.

FIGURE 4-A
HIGH FLOW CALIBRATION

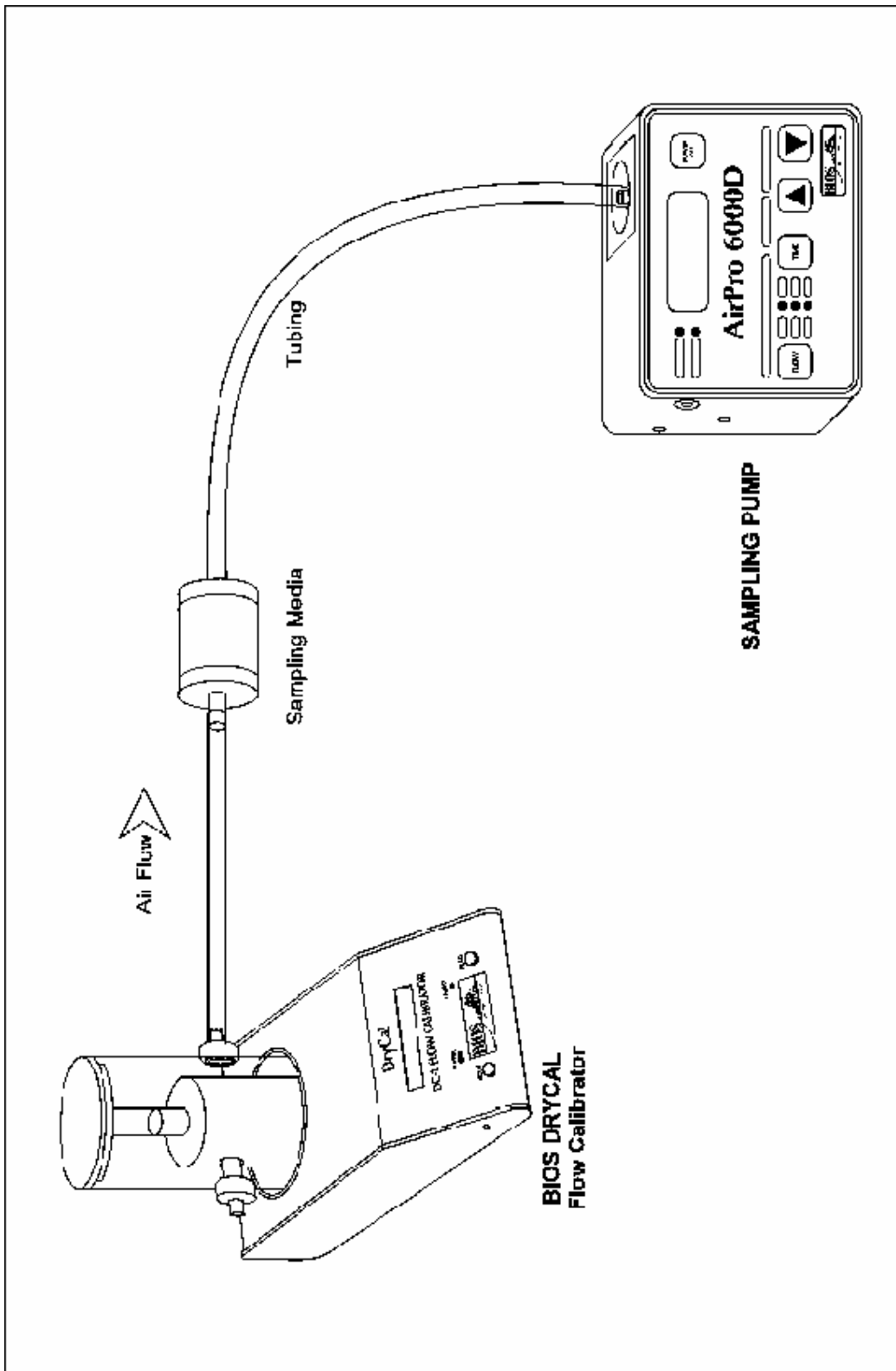

4.9 CALIBRATING THE SET FLOW RATE (HIGH): *(Continued)*

(Refer to "FIGURE 4-A, HIGH FLOW CALIBRATION SETUP")

1. With POWER-ON and Flow Rate Set Point established,
Press: <PROGRAM MODE> key, the "ADJ" LED illuminates and the pump will begin running. The display indicates the flow rate selected with a "C" prefix. At this time, you will calibrate the sampler.
2. With calibrator in-line per figure 4-A,
Press keys <▲> or <▼> to Increase or decrease and adjust the sampler until the set flow and calibrator readings agree to within 1% or as close as possible. *(NOTE: The pump's display data will not increase or decrease, but audible changes in the pumps rpm's can be observed. Allow a period of at least 20 seconds for the flow to adjust to any increment changes and for calibrator to respond.)*
3. When set flow and calibrator readings agree to your satisfaction, press the <PROGRAM MODE> key to return to the PAUSE state. The sampler is now calibrated and ready for deployment at the set flow rate. Turn OFF the calibrator's power. Remove calibrator and any extra tubing.
4. To run calibrated sampler, with Power ON, deploy sampler by pressing and holding the <RUN/PAUSE> key. The pump will begin running.

4.11 PROGRAMMING TIME FUNCTIONS:

The AirPro Metalite ND/LB Samplers offer auto-prompted, on-screen programming of timing functions. The following timing functions are prompted sequentially and can be programmed in sequence or individually when needed.

4.11.1 CLEARING "ACCUMULATED TIME" FUNCTION:

When beginning a new sampling period, if Cumulated Run time is not cleared, it will continue to accumulate with the new sample period. If necessary, make note of the previous sample Run Time and clear it.

1. With POWER-ON, Press the <RUN/PAUSE> and <▲> keys simultaneously. The display indicates the flow set point while continuing to hold keys down.

4.11.2 SETTING THE "RUN TIME" FUNCTION:

1. With POWER-ON, Press the <PROGRAM MODE>> key once, the "RUN" LED will illuminate. (The display will indicate the default run time (: 00) and the "STOP" LED will illuminate.)
2. Press <▲> or <▼> keys to Increase or Decrease the amount of time required. Time is indicated in hours and minutes. Pressing and holding the up or down keys will increase selection speed.
3. When desired time is indicated, press: <PROGRAM MODE> key once to set Delay Start Time, the "DELAY" LED will illuminate. Or Press the <PROGRAM MODE> key again to return to the PAUSE state.

NOTE: The sampler will retain all programmed RUN TIME information until the user resets this function to a

different amount.

4.11.3 SETTING THE "DELAY START TIME" FUNCTION:

To set DELAY START TIME function from PAUSE state, begin with step 1. If "START" LED is illuminated, begin with step 2.

1. With POWER ON, Press: <**PROGRAM MODE**> key twice, the "DELAY" LED illuminates. The display indicates a minus symbol before the Delay Start Time data.
2. Press: <**▲**> or <**▼**> key to Increase or Decrease in one-minute increments.
3. When desired Delay Start Time is indicated, Press <**PROGRAM MODE**> key once to return to the PAUSE state.

NOTE: The sampler will retain all programmed DELAY START TIME information until the user resets this function to a different amount. Actual Flow or Run/Delay times can be displayed at any time during the sample period.

4.12 ENTERING CONSTANT PRESSURE MODE: (LOW FLOW & MULTI-TUBE)

(Refer to "FIGURE 4-B, LOW & MULTI-FLOW CALIBRATION SETUP")

The constant pressure mode is used for low flow or multi-flow sampling. A BIOS airflow calibrator will be necessary to verify the low flow rate of each tube position or media being used. This is accomplished in conjunction with a multivariable orifice manifold and tube holder(s).

Equipment required:

AirPro Metalite ND/LB Personal Air Sampler, BIOS DryCal Calibrator, Variable Orifice Manifold, Air Bleed Accessory (Supplied with sampler, 1/8" diameter tube containing a small hole, is inserted in the tubing train between the sampler and the variable orifice manifold.) tubing, sampling media (sorbent tube holder.

1. With the POWER ON, Press and hold: <**PROGRAM MODE**> key until, the "SET" LED illuminates and "CAL" appears on the display.
2. Press: <**▲**> or <**▼**> keys to increase or decrease the flow set point until "P-.00" is indicated on the display. When "P-.00" is indicated, the sampler is in the Constant Pressure Mode.)
3. Press: <**PROGRAM MODE**> key once, the "ADJ" LED illuminates and the display indicates with a "C" prefix. The pump will run while in the calibration mode.
4. Or Press the <**PROGRAM MODE**> key once to return to the PAUSE state. Sampler is now set in the Constant Pressure mode.

4.13 LOW AND MULTI-FLOW PUMP CALIBRATION

(Refer to "FIGURE 4-B, LOW & MULTI-FLOW CALIBRATION SETUP")

1. With POWER-ON, and sampler in Constant Pressure Mode,
Press: <**PROGRAM MODE**> key twice, the "ADJ" LED illuminates and the display indicates the flow rate selected with a "C" prefix. Sampler is running.
2. With sampler and calibrator in line per Figure 4-B, set the flow rate of one sample at a time. Turn the needle valve adjust screw either (CLOCKWISE to Decrease) the flow rate, or (COUNTER-CLOCKWISE to Increase). Verify the flow on the DryCal display. Continue with this procedure for each sample. Flow readings should agree within 1%.
3. When flow is set to your satisfaction, press the <**PROGRAM MODE**> key to return to the PAUSE state. The sampler flow rate is now calibrated. Remove the calibrator and any extra tubing. The sampler is in the PAUSE state.
4. To run calibrated sampler, with Power ON, deploy sampler by pressing <**RUN/PAUSE**>. The pump will begin running.

FIGURE 4-B
LOW & MULTI-FLOW CALIBRATION SETUP

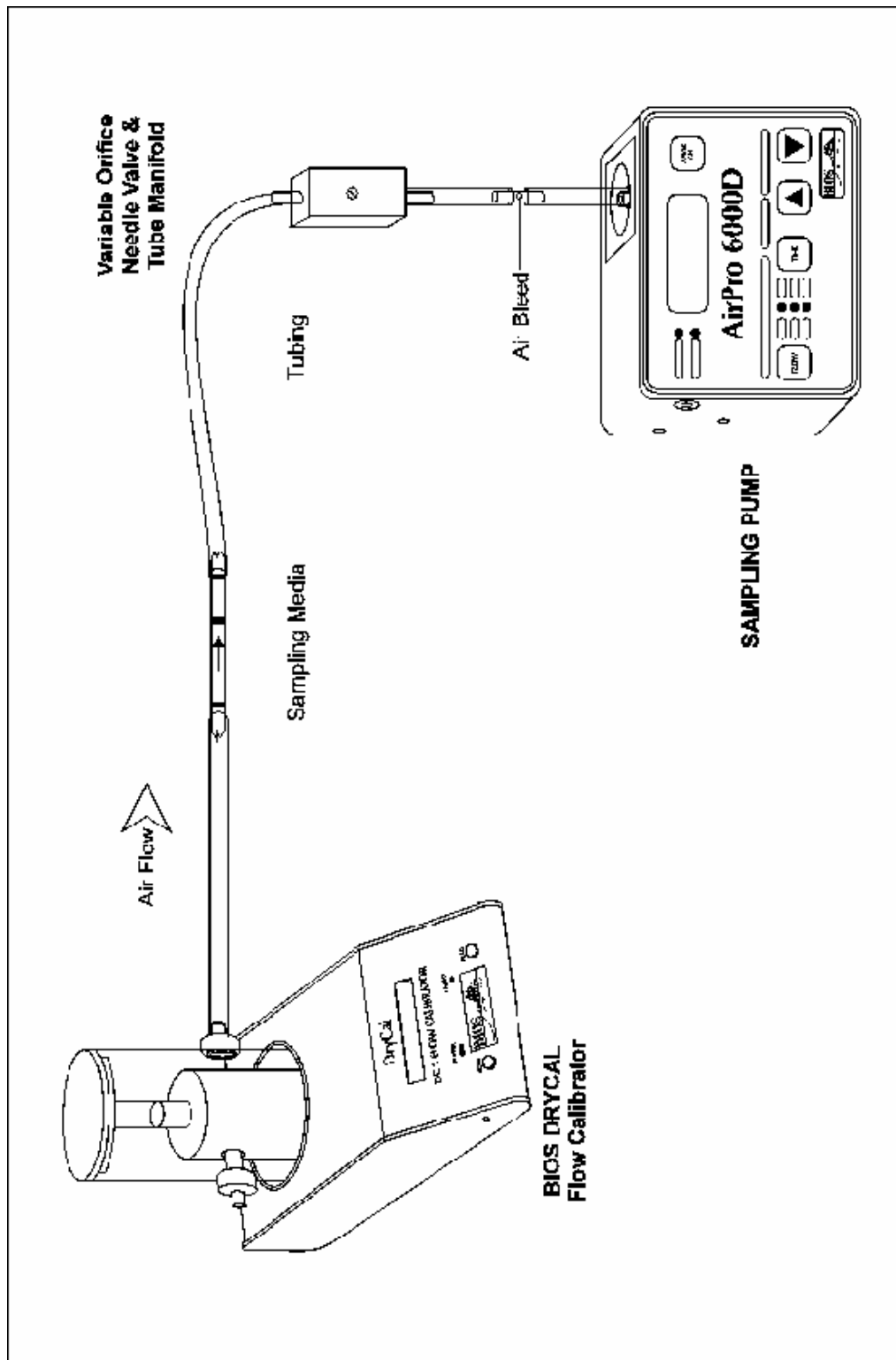

4.14 USING THE ANTI-TAMPER PLATE

The Anti-Tamper Plate prevents inadvertent tampering to the flow and time settings of the sampler.

TO SECURE THE ANTI-TAMPER PLATE:

1. Lay over faceplate and tighten two phillip head screws with screwdriver.

NOTE: Be sure to set pump on to desired flow rate before securing Anti-Tamper plate

TO SECURE THE ANTI-TAMPER PLATE:

1. Loosen two phillip head screws with screwdriver and remove Anti-Tamper plate

4.15 ELECTRONICS REVISION LEVEL

If you would like to observe the revision level of your sampler electronics, this procedure accesses the electronics revision level information.

1. With POWER-OFF, Press and hold: <▲> key. While continuing to hold, press the <ON> key once. The revision level will be indicated as long as the <▲> key is held.
2. Upon release of the <▲> key, the unit will return to the RUN non-programmed state.

5.0 TROUBLESHOOTING

The following troubleshooting guide can assist you in answering some common questions and operating procedures for the AirPro Metalite ND and LB Air Samplers. Please review this section completely before calling to return your pump to BIOS International for service.

WARNING:

Care must be taken to prevent any corrosives or liquids from entering the pump's interior. This could lead to personal injury, severe pump or electrical problems.

5.1 DISPLAY MESSAGES, ERRORS, FAULTS

[HI P]	PRESSURE FAULT. If excessive back pressure is not reduced, the unit will shut down in 20 seconds.
[BAT]	BATTERY LOW. The battery has discharged to a level that could damage the battery. The unit will shut off on this error in 20 seconds.
[LO BAT]	LOW BATTERY. The battery has discharged to a level that requires recharging.

5.2 UNIT DISPLAYS "HI P" MESSAGE (PRESSURE FAULT).

Solution (a):

Check for obstruction in flow path: pinched tubing or clogged sample media.

Solution (b):

Sampling train may exceed pump capacity. Be sure that the sample media does not exceed pump performance capability at selected flow rate.

(I.e.; 4 Lpm through a sorbent tube.)

Solution (c):

Check filter screen and clean if necessary.

Also, see 6.6 CLEANING/ REPLACING THE DAMPER FILTER SCREEN".

Solution (d): (Advanced)

A bad bearing or pump motor (usually becoming noisy). Possible Pump Motor Assembly replacement required. Contact BIOS Repair Dept. for assistance.

Solution (e):

Fault: electronics. Possible PC board Assembly replacement required.

Contact BIOS Repairs Dept. for assistance.

5.3 UNIT DISPLAYS "BAT" MESSAGE (BATTERY LOW).

Solution (a):

See "5.4 Pump Will Not Turn ON."

Solution (b):

Possible PC board Assembly replacement required.

5.4 PUMP WILL NOT TURN ON AND DISPLAY NOT INDICATING.

Solution (a):

Battery may need to be fully charged. Be sure correct charger is being used. *Also, see "4.1, CHARGING THE BATTERY SYSTEM".*

Solution (b):

Battery may be disconnected. Remove the four- (4) screws on the rear of the case and check that the battery connector and leads are secured.

Also, see "6.1 CASE DISASSEMBLY PROCEDURE".

Solution (c): (Advanced)

If possible, measure battery pack output between the red and black wires with a voltage meter. The AirPro Metalite ND uses a 6.0 volt Nicad battery pack. The 6000D uses a 12.0-volt battery. If the level indicates low after full charging, the battery assembly may need to be replaced. Call BIOS Repairs Dept. for assistance.

5.5 PUMP SHUTS OFF WHEN ATTEMPTING CALIBRATION OR RUN MODES AND DISPLAY EXTINGUISHES.

Solution (a):

Battery may need to be fully charged.

Solution (b):

Electronics may have been damaged. Check PC board.

Also, see "Warning" note.

5.6 PUMP DOES NOT RUN IN SAMPLE MODE:

Solution (a):

Battery may need to be fully charged.

Solution (b):

The sampler may have a preset DELAY start time.

If the sampler has not yet reached "00", the pump will not run.

Also, see "4.9.3, SETTING THE DELAY START TIME FUNCTION".

5.7 BATTERY LED INDICATES "CHARGING" AND SAMPLER DOES NOT TURN "ON" OR "RUN".

Solution (a):

Battery lead may be broken or disconnected.

Solution (b):

Battery may have blown fuse. Replace Battery.

Also, see "5.4 PUMP WILL NOT TURN ON".

5.8 SAMPLER DOES NOT PERFORM EIGHT HOURS OF SAMPLING.

Solution (a):

Battery may need to be fully charged. Be sure correct charger is being used.
Also, see "4.1, CHARGING THE BATTERY SYSTEM".

Solution (b):

Battery or charger may be defective. Possible replacement required. Contact BIOS Repairs Dept. for assistance.

Solution (c):

Sampling train may exceed pump capacity. Be sure that sample media does not exceed the pump performance capability at selected flow rate, i.e. 4 Lpm through a sorbent tube.

Solution (d):

Defective bearing, Pump Motor Assembly or PC Board.
Possible replacement required. Contact BIOS Repairs Dept. for assistance.

5.9 "CHARGING" LED DOES NOT ILLUMINATE.

Solution (a):

Be sure correct charger is being used.
Also, see "4.1, CHARGING THE BATTERY SYSTEM".

Solution (b):

Be sure that charger is plugged into "live" wall outlet.

Solution (c): (Advanced)

Measure voltage of charger with voltmeter. (ND=12-15V, LB=20-24V.)

Solution (d):

Possible PC board Assembly replacement required. Contact BIOS Repairs Dept. for assistance.

5.10 SAMPLER RUNS FULL OUT WITHOUT ANY FLOW CONTROL.

Solution (a):

Pump may be preset to Constant Pressure Mode. Be sure that a variable orifice and air bleed is used in-line with the pump in this mode.
Also, see "4.0 ENTERING CONSTANT PRESSURE MODE".

Solution (b):

Inspect Filter Damper Assembly for leakage. Replace if needed.
Also, see 6.6 CLEANING/REPLACING THE DAMPER FILTER SCREEN".

Solution (c):

Pump Diaphragm may have failed. Possible Pump/Motor Assembly replacement required. Contact BIOS Repairs Dept. for assistance.

5.11 SAMPLER GIVING INCORRECT FLOW AS COMPARED TO CALIBRATOR.

Solution (a):

Check sampling train for leaks: connection of tubing, fittings, media, etc.

Solution (b):

Inspect Filter Damper Assembly for leakage. Replace if needed.

Also, see "6.3 REMOVING THE PUMP/MOTOR AND DAMPER/FILTER ASSEMBLIES".

Solution (c):

Inspect filter screen and clean if necessary.

Also, see 6.6 CLEANING/ REPLACING THE DAMPER FILTER SCREEN".

Solution (d):

Pump Diaphragm may have failed. Possible Pump/Motor Assembly replacement required.
Contact BIOS Repairs Dept. for assistance.

Solution (e):

Bad bearing or pump motor (usually becoming noisy).

Possible Pump Motor Assembly replacement required.

Contact BIOS Repairs Dept. for assistance.

6.0 TECHNICAL REPAIRS AND SERVICE

There may be need to disassemble the sampler to replace, clean or examine the condition of certain parts and assemblies, i.e.; Filter, Diaphragm, wire connections, etc. The following information is provided to guide you through proper maintenance of your equipment without injury or damage. These procedures will instruct you on how to open the sampler case, remove major assemblies, and replace spare parts.

NOTE: See "8.0, PARTS LIST" for full listing of replacement parts available for this product.

REQUIRED TOOLS:

- 1- #1 & #2 Philips screwdrivers
- 1- Regular flathead screwdriver
- 1- Small 1/4 wrench or pliers

FIGURE 6-A
PUMP DISASSEMBLY OVERVIEW

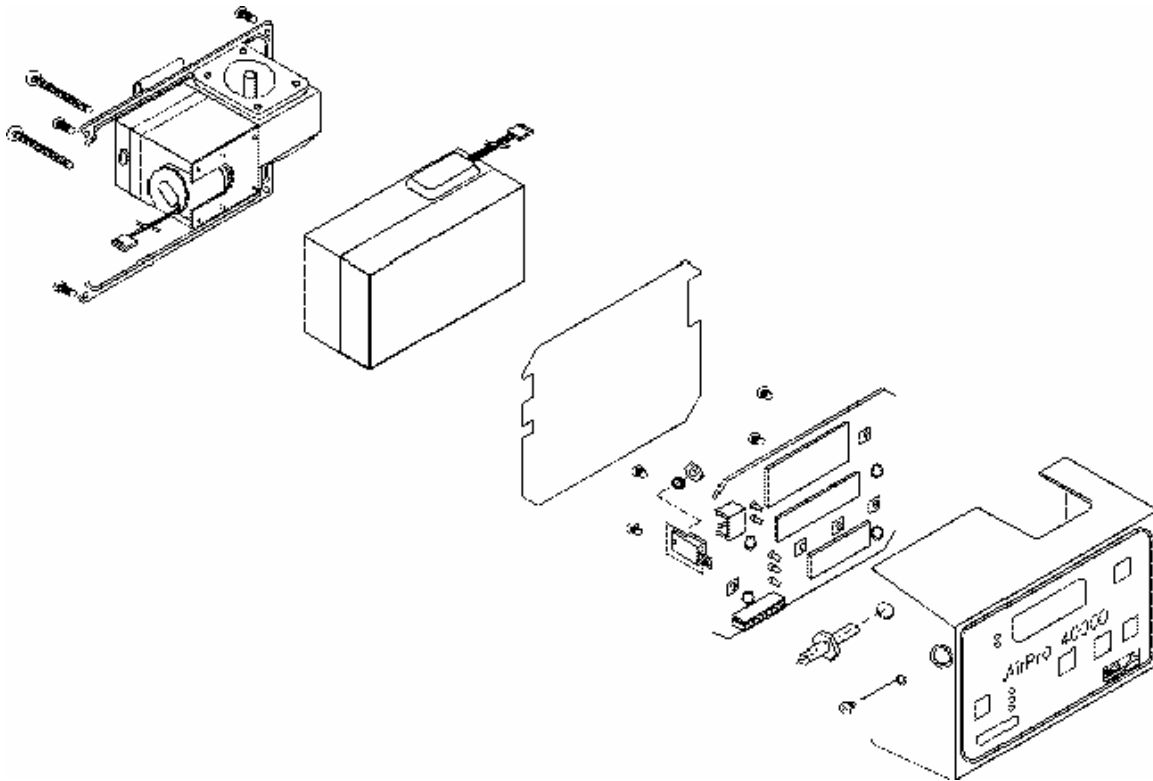

6.1 CASE DISASSEMBLY PROCEDURE:

1. Lay sampler face down on a stable, non-scratch surface.
2. Remove the four (4) silver screws from side of case. Retain screws for reassembly.
3. While holding case assembly together, turn unit over so that the facel is now facing you.
4. Carefully lift cover off the unit and open to the right like a book.
5. Disconnect the Pump (2-wire) and Battery Pack (3-wire) connectors.

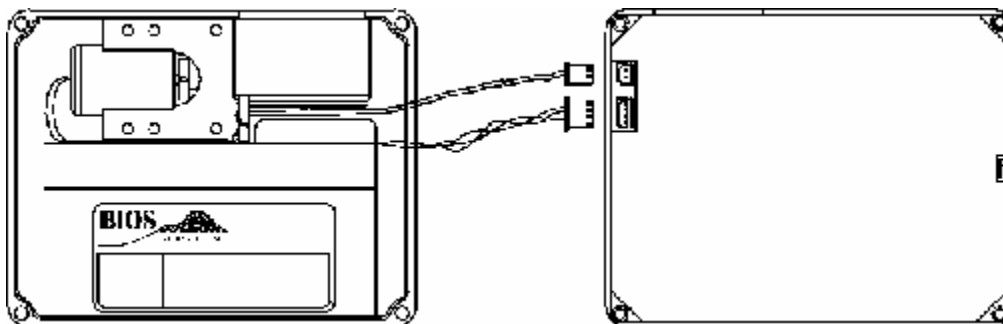

6.2 REMOVING THE BATTERY PACK ASSEMBLY:

1. First, perform “6.1 CASE DISASSEMBLY PROCEDURE”
2. Disconnect Battery connector (3-wire) and lift battery pack away from case front.
3. When reinstalling battery pack, make sure connector is to your right. Reconnect to lower receptacle on case back.

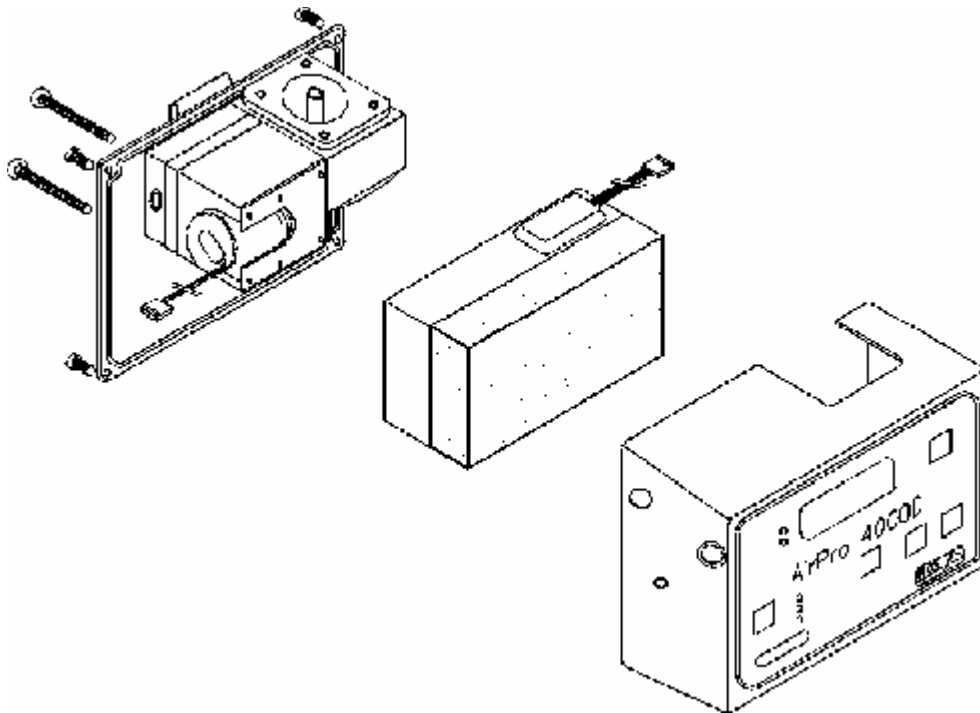

6.3 REMOVING THE PUMP/MOTOR and DAMPER/FILTER ASSEMBLIES:

1. First, perform “6.1 CASE DISASSEMBLY PROCEDURE”
2. From belt clip side of case back, remove all three (3) black 4-40 Phillips-head screws.
NOTE: The (1) 1/4" short screw secures the Damper/Filter Assembly and the (2) 1-5/8" long screws secure the Pump/Motor Assembly to the Case Back.
3. Together, lift the Pump/Motor and Damper/Filter assemblies away from the case back.
NOTE: The motor wiring harness is wrapped around the metal stud on the Damper/Filter Assembly.
4. Gently untwist and separate the Pump/Motor Assembly from the Damper/Filter Assembly.

NOTE: Be careful not to touch or puncture the Damper/Filter Assembly diaphragm.

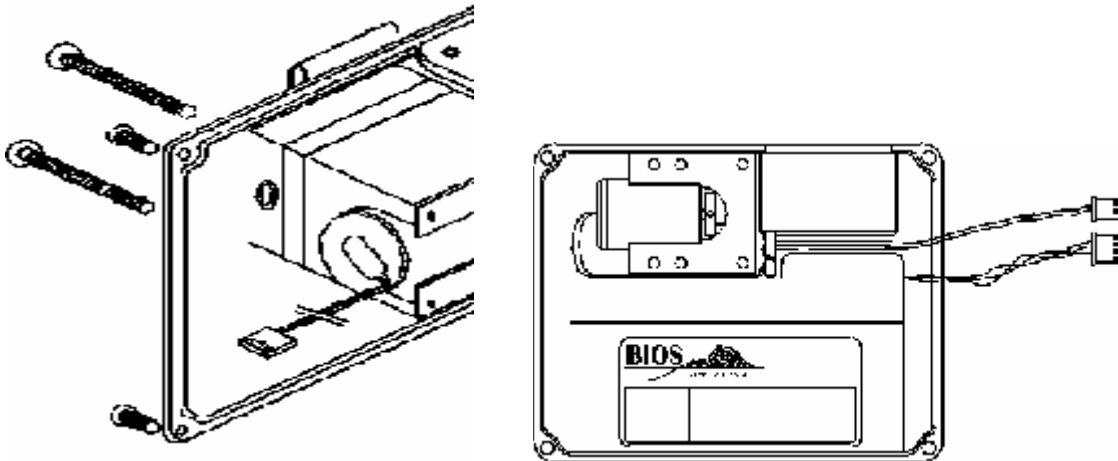

6.4 REMOVING PC ELECTRONICS BOARD ASSEMBLY:

1. First, perform “6.1 CASE DISASSEMBLY PROCEDURE”
2. Remove protective gray insulator covering from inside the Case Front.
3. On the LB model only, use a wrench or pliers and Phillips screwdriver, hold inside nut on transistor and remove outside black screw. Retain for reassembly.
NOTE: The plastic shoulder insulator is located inside the transistor-mounting hole.
4. Carefully remove four (4) slotted screws holding PC board to case front.

WARNING: Be careful not to exert excessive force or to scratch PC board.

5. Grab transistor and gently lift the PC board out of the case back. Be careful not to bend transistor lead during removal. (LB only)

6.5 REINSTALLING PC BOARD ASSEMBLY:

1. Grab PC board transistor and slowly insert the PC board into the case back. Gently press so as to align case front holes with board and side case hole with transistor.
2. Insert side screw first and secure gently. Be careful to seat Insulating Washer. Failure to do so may cause failure. Do not over-tighten. Next, position all four (4) PC board screws and secure gently.
3. Replace gray insulator covering to inside case front.

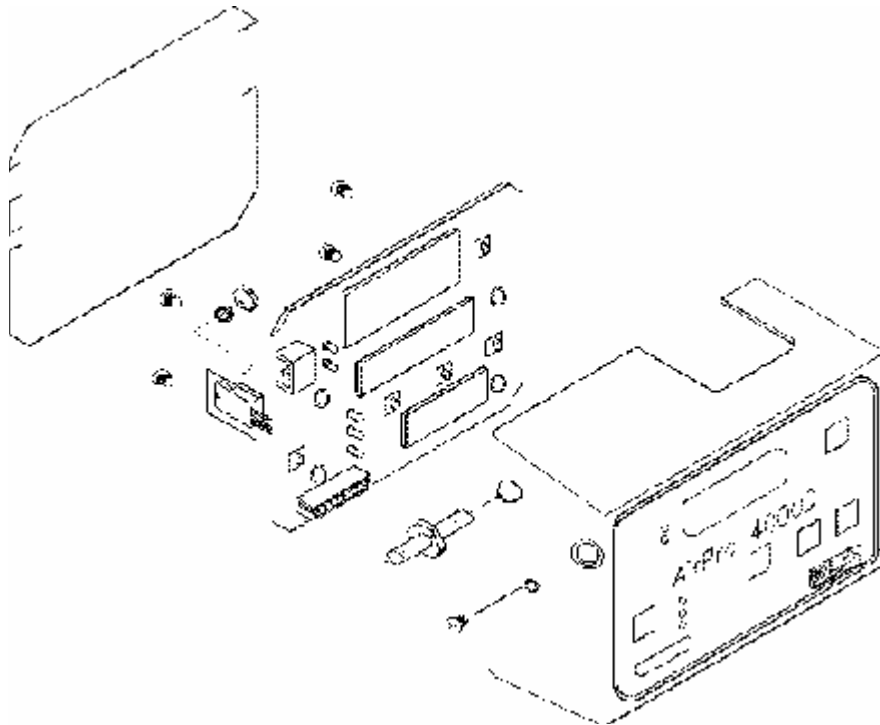

6.6 CLEANING/ REPLACING THE DAMPER/FILTER SCREEN:

This procedure is performed with the sampler in a semi-assembled state. With the sampler sitting facing you, the air inlet is located at the top right.

1. Remove the four (4) black Phillips head screws securing the Air Inlet top plate to the top of the Air Inlet Filter Assembly. Retain for reassembly.
2. Loosen the four (4) silver screws on the case back slightly.
3. Grab the Inlet top and gently lift out of case.
4. Remove the O-ring. Sometimes it is stuck to the Inlet Top itself.
5. Remove the filter screen by tilting the sampler and dropping the screen into your hand.
6. You can examine the screen and determine whether cleaning or replacement is required. To clean, use a small brush with soap and water. Dry screen completely before reinstalling.
7. Replace screen, O-ring and Inlet Top. Replace the four (4) black screws and secure. Do not over tighten screws.

NOTE: The Inlet Top must be positioned so that its one flat edge faces the case back position. Simply turn the Inlet Top until it fits properly into the opening. Retighten case back screws.

7.0 MAINTENANCE, STORAGE, SHIPMENT

7.1 MAINTENANCE:

Keep equipment clean and free of dirt and dust buildup. Wipe only with a damp cloth. Do not submerge sampler in water. Do not spray or use abrasive cleansers.

7.1.1 Calibrate pump as needed prior to sampling.

Also, see sections 4.8 & 4.11, HIGH AND LOW FLOW CALIBRATION.

7.2 LONG-TERM STORAGE:

Samplers can be left on "Charging" until needed or stored in a clean, dry environment. Equipment should be recharged and re-calibrated prior to use after long-term storage.

Also, see "4.2 BATTERY MAINTENANCE AND STORAGE".

7.3 SHIPMENT OF EQUIPMENT:

Equipment can be shipped in original packaging or wrapped with foam inserts for protection.

8.0 PARTS LIST

<i>Part Number:</i>	<i>Description:</i>
AirPro Metalite ND/LB Common Parts List	
A/CASE3	Carrying Case, 5-Pack, <i>(Includes foam and label)</i>
A/PSAMPEN	Pump Enclosure, metal <i>(No hardware included)</i>
ES4	Screws, Enclosure, 4-pack
PAMS2	Screws, for mounting Pump Assembly, 2-pack
CBMS4	Screws, for mounting Control Board, 4-pack
A/DAMPER2	Damper, made with Silicone
VALVE HEAD	Pump head, <i>(No motor included)</i>
A/AIRBOSS	Air Boss, Accessory
A/ARBLEED	Air Bleed, Accessory
BELTCLIP1	Belt Clip, <i>(Includes screws)</i>
FISHINSUL	PC Insulator, for inside enclosure
AirPro ND Only	
4000A/PUMP1	Pump/ Motor Assembly, <i>(Screws not included)</i>
A/4000D	Control Board, <i>(Includes conformal coat)</i>
	Battery Pack, AKA-A, BL6V1.3
BC4000D	Battery Charger, Single-Station, 120V
BC4SS240	Battery Charger, Single-Station, 240V
BC4MS120	Battery Charger, 5-Station, 120V
BC4U	Battery Charger, 5-Station, Universal (90-250V)
LAP4000D1	Label, UI Label, <i>(4000D)</i>
AirPro LB Only	
6000A/PUMP1	Pump/ Motor Assembly, <i>(Screws not included)</i>
A/6000D	Control Board, <i>(Includes conformal coat)</i>
BA12V1.2A	Battery Pack, AKA-A, BL12V1.2
BC6000D	Battery Charger, Single-Station, 120V
BC6MS120	Battery Charger, 5-Station, 120V
BC6MS240	Battery Charger, 5-Station, 240V
BC6U	Battery Charger, 5-Station, Universal (90-250V)
LAP6000D3	Label, UL, <i>(6000D)</i>

9.0 GLOSSARY OF COMMON AIR SAMPLING TERMS

“MEDIA”

An assortment of sample devices designed to collect particles gases and vapors into or onto a filter surface, sorbent or liquid. The most common sampling media include Sorbent Tubes, Filter Cassettes, Gas Sampling Bags, Cyclones and Impingers.

“FLOW RATE”

The rate at which the sampling device draws air through the sample media.

“BACK PRESSURE”

The condition that occurs in opposition to flow rate when flow rate is restricted, i.e. crimped hose, particulate buildup on filter cassette, orifice restriction.

“IN-LINE”

Refers to when sampling media is connected to the sampling device, such as a filter cassette or sorbent tube cassette to an air-sampling pump via a piece of tubing. An "in-line" configuration can be connected to a calibrator to simulate the back pressure conditions of the proposed application, while performing the calibration procedure.

“PERSONAL SAMPLING”

Applications which require a portable sampling device to be worn by the worker to monitor exposure to airborne hazards. Typically the "media" is positioned within workers breathing zone.

“STATIONARY SAMPLING”

Applications that employ the use of high flow pumps to sample large areas, work stations, small rooms, warehouse, process piping, shipping hulls. It can also be used to map Indoor Air Quality (IAQ) exposures.

“HIGH FLOW SAMPLING”

High flow sampling with the AirPro 4000D or 6000D is typically 750 to 6000 ml/min. at "Constant Flow" rate. Common air sampling applications at this flow rate include filter cassettes, cyclones. NIOSH and OSHA require sampling pumps to be calibrated within $\pm 5\%$ of the recommended flow rate and with the sampling media in-line.

“LOW FLOW SAMPLING”

Low flow sampling is typically at 1-1000 ml/min. At this low flow rate, applications usually include single or multiple sorbent tube(s), impingers, and gas sampling bags. To achieve multi-flow sampling, the pump must maintain "Constant Pressure" to allow external adjustment of flow across a variable orifice manifold, allowing each tube an independently set flow rate.

“CONSTANT FLOW”

Constant Flow is typically associated with High Flow sampling. A true constant flow mode automatically compensates for varying back pressures due to sample flow restriction; (i.e., crimped hose, buildup of particles or aerosols on the filter surface) and maintains the flow rate constant.

“CONSTANT PRESSURE”

Constant pressure is typically associated with low flow sampling for multiple sorbent tubes (replicate sampling), but on occasion is used for dual sampling at higher flow rates. The sampling pump establishes and maintains a constant pressure condition internally. This condition enables multiple sampling capability via an external flow adjustment device, i.e., a multiple-variable orifice manifold allowing each port an independently set flow rate.

“CALIBRATION”

When setting sampler flows with media in-line, an air flow calibrator is necessary to verify the actual flow rate.

“EMI/RFI SHIELDING”

Electromagnetic and Radio Frequency Interference are generated by sources such as 2-way radios, communication headsets, unshielded motors and can be major enemies of air sampling electronics. A pumps unshielded electronic circuit is penetrated and the electronic flow is upset causing inaccurate flow and timing performance and ultimately inaccurate collection data. EMI/RFI shielding protection is provided on AirPro Samplers with an all-metal case.

“INTRINSIC SAFETY/ UL”

The sampler's intrinsic safety to the user is rated by an outside agency such as Underwriters Laboratory Inc. (UL). This symbol and approval rating ensure the user that the sampler has been tested in the environment for which it is to be used, meets and conforms to all safety requirements for that usage.

BIOS AirPro 4000D & 6000D Personal Air Samplers are UL approved intrinsically safe for use in hazardous locations class I, groups A, B, C, D, class II, groups E, F, G and class III. UL Listed 87Y4, Temperature Code T3C, Made In U.S.A. To maintain intrinsic safety integrity, use only BIOS battery pack and replacement spare parts approved for AirPro 4000D & 6000D.



BIOS International Corporation

10 Parkway Place, Butler, NJ 07405 U.S.A.

Phone: 973-492-8400

Toll Free: 800-663-4977

Fax: 973-492-8265

© 2000, BIOS International Corporation, Form #MANMLT-Word7, Rev. X, 6/1/00